



Laboratory Bench Systems



DISCOVERY BENCH SYSTEMS

18784 – 174TH Avenue
Spring Lake MI 49456
Ph: 616-846-6990
www.keurind.com

TABLE OF CONTENTS:

KEUR INDUSTRIES INC.

Discovery Bench Systems

Bench Systems Specification	1
General Information	4
Discovery™ series (2"x6" framing) Single/Double Sided	5
Discovery LT™ series (2"x3" framing) Single/Double Sided	9
Discovery LT™ series (2"x3" framing) Floor Mounted System	12
Bench top Shelving	13
Discovery LT™ series (2"x3" Framing Fixed H-LEG Framing)	14
Discovery™ series (2"x3" Fixed Floor Mounted System)	17
EKO™ series (Fixed and Mobile tables)	18
Accessories	20

Bench Systems Specification Information

This guide is a tool to help build working environments suitable for this product's application. Each component has a specific part number so as to easily track and cost projects. Each style or system has advantages and disadvantages. You must review each to find the best fit. Cost, flexibility, usage, and environment will determine the best solution. Each application comes in a powder-coated steel, aluminum, or polished stainless steel. See our catalog for casework.

General information relating to framework and specifications

Selecting the system that best suits your needs

1. **Frame System Selection and material type – Carbon steel, aluminum, or stainless steel. Note only carbon steel will need a powder coat finish. Gauges range from 16 up to 11 gauge based on model and material selected.**
2. **Each frame system uses support structure to build bench modules from the floor up or off a work surface. Unless utilizing the Vision or Lynx ceiling service systems, see that specific section.**
3. **Lengths are typically nominal sizes of 3, 4, 5, and 6 foot with options for special applications including corners.**
4. **Frame upright tubes by product description**
Discovery – 2" x 6" steel tube 11 gauge (stainless steel will be 14 gauge)
Discovery LT – 2" X 3" steel tube 14 gauge with stainless steel the same
Euro – 2" x 10" steel extrusion with radius ends gauge 14 only
Vision – Bench not released
Eko – 2" x 2" steel tube 14 gauge (stainless steel will be 16 gauge)
Eko LT – 1" x 3" steel tube 14 gauge (stainless steel will be 16 gauge)

Note: All square or rectangle carbon steel tubes that are 2" and under use ASTM A-500 grade B material. While the 1" X 4" tube will be a ASTM-513 type.

- 1"x3" = weight per foot 2.16 lbs 14 gauge
- 2"x2" = weight per foot 2.164 lbs 14 gauge
- 2"x3" = weight per foot 3.9 lbs 14 gauge
- 2"x6" = weight per foot 6.46 lbs 11 gauge

Mechanical properties of the upright structural tubing:

All surfaces are mechanically cleaned in the forming process. Soil oil, grease, loose mill scale removed prior to powder coating.

All components including framing if carbon steel will be treated in a light etching bath and wash cycle before oven drying. After oven drying the pre-determined powder color is applied. The powder-coated parts are then cured in an oven for a specified timed cycle to create the best possible finish.

Casework and storage selection see either separate catalogs or contact your sales representative.

5. **Accessory options – Your options include shelving systems such as flat, seismic, bookend type, dished, or angled. The upright tubes can be pierced two ways one: is with standard slots; the other is a round with a ¼-20 insert for supporting shelving. A combination of both can be used as well.**
6. **Other accessory options include electrical and data ports or add on options. You can choose from using a standard conduit direct connection to a single junction box or a more modular application by using our modular power components. Note the modular power can only be used on the Discovery, Discovery LT, Vision, and Euro systems.**

7. Each bench module can be equipped as well with data ports. We currently use a Panduit© snap in type connector. This 6-port system allows for your internal phone, Ethernet, or direct cable systems to be incorporated into your design. We also offer the option to add the system you currently use and will engineer the system in as required. For more options and information see the electrical portion of this catalog.

Static mounting conditions have a couple of options for leveling devices. Each device is rated for a minimum of 1,500 lbs. With heavier loads use the HD version of the leveling device. The levelers use a minimum of a 3/8-18 type thread with a material of chrome plated steel or stainless steel. The pad is a non-marking neoprene black in color. For seismic conditions we offer a pad with a built in floor securing option to meet local and state codes for these conditions. We also have add on seismic bracing and stabilizing devices.

8. Mobile – each system has the option to have casters added for mobility if this option best suits your needs. We can also incorporate quick disconnect power and plumbing options as required for your project. Casters are NSF approved non-marking type with locks. Caster types and sizes are based on information presented by the customer for load capabilities and operational environment. This will also dictate size and type of caster required to best meet the presented requirements.
9. Selecting work surfaces – Material information only. For more detail see that section.
 - A. Materials for use with these bench systems include but are not limited to steel, 304 & 316 stainless steel, perforated stainless steel, plastic laminate, ESD compliant work surfaces, plastic, phenolic resin, epoxy resin, wood, and ceramic based materials.

*Accessories not shown with benches. See accessories catalog or contact your representative.
Special add on features include:*

Monitor arms and add on accessory options

PC carriers for under the counter or side mounted

Key board trays various sizes and material types including stainless steel

Marker boards and slat walls

Divider panels or end panels of stainless steel, steel, laminate, clear acrylic, frosted acrylic, epoxy, or phenolic resin.

ADA compliant stations or module sections with hand crank or power lift options. These individual stations can be incorporated in with each type of bench systems as required. Typical lift capabilities are 1,100 lbs. per station.

More accessories are available. For information, contact your dealer or representative.

For help in selecting your system contact your local dealer

Lab Bench Systems

DISCOVERY™ FRAME SPECIFICATIONS				VISION™, EKO™ & EURO™ FRAME SPEC			
	DISCRIPTION	GAUGE	MATRL.		DISCRIPTION	GAUGE	MATRL.
1	Standard frame construction	11	CRS	1	Standard frame construction	14	CRS
2	Cantilevers standard	11	CRS	2	Cantilevers standard	11	CRS
3	Cantilevers heavy duty	14	CRS	3	Cantilevers heavy duty	14	CRS
4	Shelving standard	16	CRS	4	Shelving standard	16	CRS
5	Suspension kits	11	Stn. Stl.	5	Suspension kits	14	CRS
6	Bridges standard	16	CRS	6	Bridges standard	16	CRS
7	Feet all sizes	14	CRS	7	Feet all sizes	14	CRS
8	Dividers steel	18	CRS/Stn. Stl.	8	Dividers steel	18	CRS/Stn. Stl.
9	Vertical supply chase	20	CRS	9	Vertical supply chase	20	CRS

ALL SYSTEMS UNLESS SPECIAL:

Note: This system is also sold in type 304-stainless steel.

This system is a bolt-together assembly using the components listed below to complete.

- A. Feet bolt into uprights to complete one upright assembly. All uprights and feet are shipped loose for easier shipping unless assembly is requested. Feet are shipped with leveling pads stainless steel with a neoprene cover non-marking. Casters and different leveling pads can be added.
- A1. Tools needed to complete the assembly are a Phillips screw driver, Allen wrenches, & end wrenches.
- B. Bridge sections are bolted into uprights various lengths. This also includes the floating system when uprights are pierced accordingly.
- C. Cantilevers bolt into uprights and are adjustable from sitting to standing heights, except for the heavy duty version which is Sold in a standing or seated version typically for supporting suspended casework or heavy equipment.
- D. Shelves bolt onto the uprights or slide in if the uprights are slotted. There are three types of shelves: gravity feed, adjustable and a standard shelf that includes a seismic lip. Shelves are welded construction with spot welded hat channel support.
- F. Work surfaces are secured to the cantilevers and are removable when needed.
- G. Accessories are added as needed to complete your assembly.
- H. Storage selected from supplied casework information. Select material and then add to the bench assembly. If suspended add kits for each bench module that requires supporting casework. Note all bench modules must use the heavy duty type of cantilever if you are using the suspended system.
- I. Submit part numbers and quantities for pricing or contact your representative for a layout design.

Discovery Bench Systems™

General Information:

The Discovery laboratory solution uses a welded rectangle tube construction. This main structure has cantilevers to hold up the work surfaces. Removable and replaceable feet, glides, shelves, and added utility chases for more capabilities. The system has various standard lengths and can be modified for a specific length where needed. This system can be specified directly by the customer or by a Keur Industries representative. Keur Industries will typically assist a customer through their applications. Architects may wish to use our symbol library to help speed up design time. General pricing is also provided to help customers make initial decision concerning their projects.

Each component used to build the system will be listed with a part number and general information explaining the part and its function. This system is fabricated from carbon steel and 304-stainless steel when required. The bench shown below will indicate basic components and where they are being used in the system. This will help you build your specific bench system.

This system lends itself well to supply data, plumbing, and electrical systems through the super structure and chase components. This system can have all your data and electrical components installed at the factory. You can also have your plumbing and electrical pre-installed up to a "J" box and piped up, down, or strait out based on needs. These are all extra charges listed in the accessories section.

Figure 1.

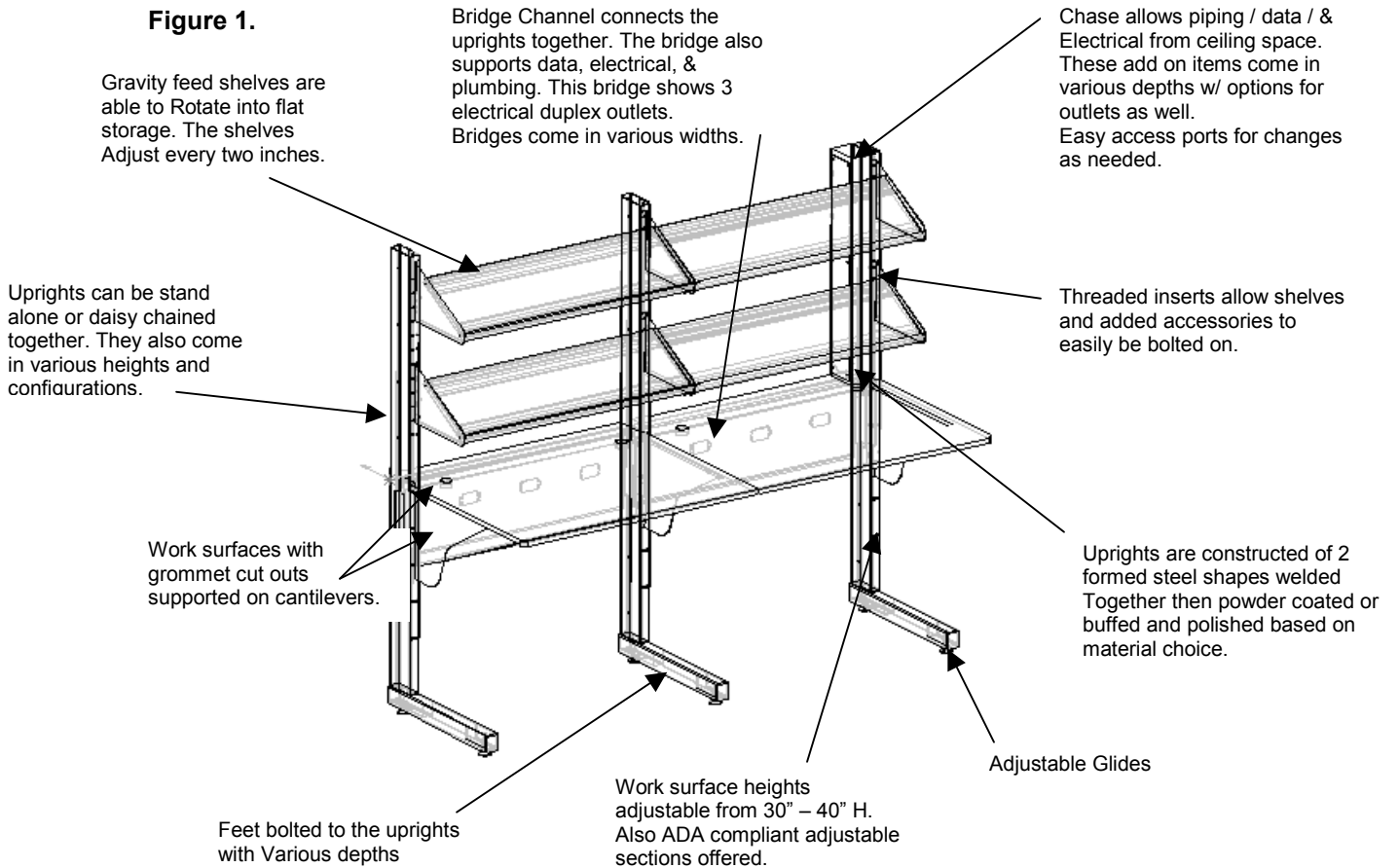

Discovery Frame System

The above Discovery Bench System layout gives you a brief overview of components offered in this specification guide. For further details refer to Figures 2 & 3.

Discovery™ series (2"x6" framing)
Select Single and Double sided standing/sitting height benches

This is where you select the modules that best fit your needs. These are the standard bench configurations without uprights going beyond the work surface. Standard widths are indicated below. Note these benches adjust from standing height to sitting. When they are adjusted down to sitting height the electrical and data ports are exposed. Work surfaces should be cut accordingly to allow for this process unless specified. Standing height configurations can use access ports or add on upper chase assemblies for power. See accessory add section.

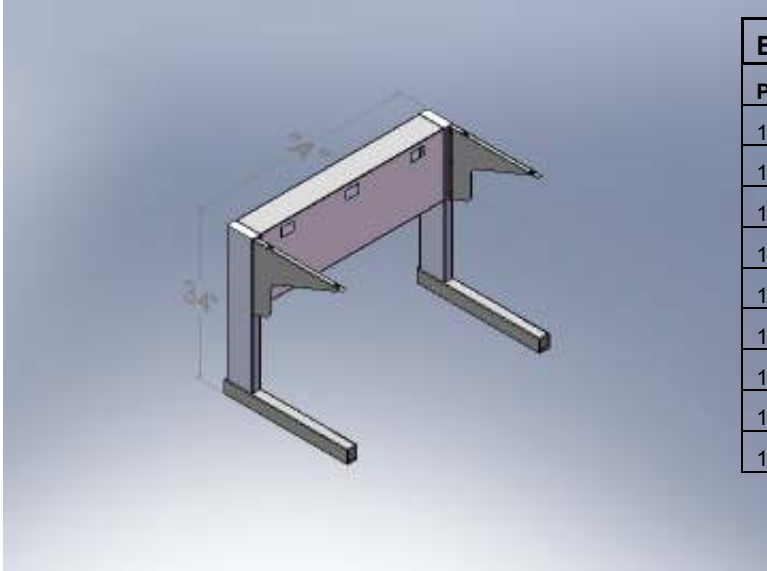

Bench Module Sizing Chart		
PART NO.	SIZE	DISC.
1SS-024-DLB-35	24"w x29"d x 35"h	Adjustable work surface height
1SS-030-DLB-35	30"w x29"d x 35"h	Adjustable work surface height
1SS-036-DLB-35	36"w x29"d x 35"h	Adjustable work surface height
1SS-042-DLB-35	42"w x29"d x 35"h	Adjustable work surface height
1SS-048-DLB-35	48"w x29"d x 35"h	Adjustable work surface height
1SS-054-DLB-35	54"w x29"d x 35"h	Adjustable work surface height
1SS-058-DLB-35	58"w x29"d x 35"h	Adjustable work surface height
1SS-060-DLB-35	60"w x29"d x 35"h	Adjustable work surface height
1SS-072-DLB-35	72"w x29"d x 35"h	Adjustable work surface height

Single sided Discovery™ bench module (standing height)

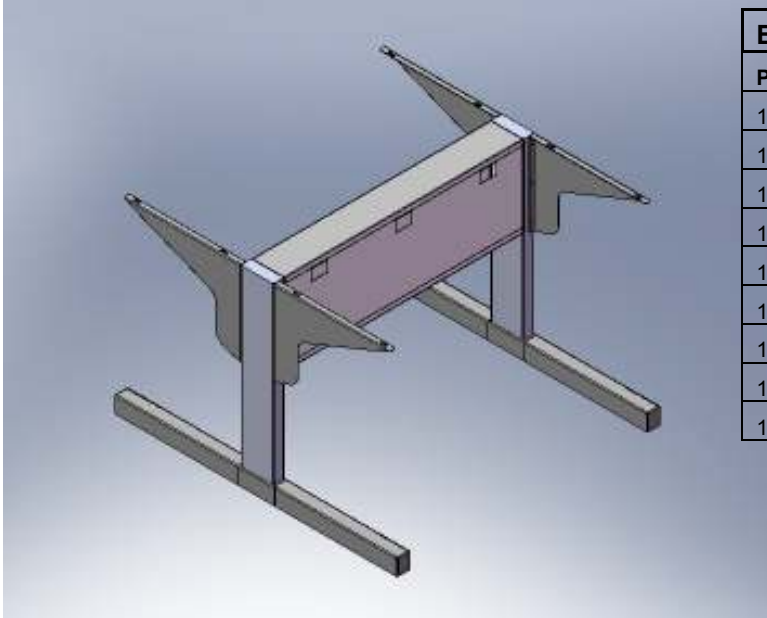

Bench Module Sizing Chart		
PART NO.	SIZE	DISC.
1DS-024-DLB-35	24"w x58"d x 35"h	Adjustable work surface height
1DS-030-DLB-35	30"w x58"d x 35"h	Adjustable work surface height
1DS-036-DLB-35	36"w x58"d x 35"h	Adjustable work surface height
1DS-042-DLB-35	42"w x58"d x 35"h	Adjustable work surface height
1DS-048-DLB-35	48"w x58"d x 35"h	Adjustable work surface height
1DS-054-DLB-35	54"w x58"d x 35"h	Adjustable work surface height
1DS-058-DLB-35	58"w x58"d x 35"h	Adjustable work surface height
1DS-060-DLB-35	60"w x58"d x 35"h	Adjustable work surface height
1DS-072-DLB-35	72"w x58"d x 35"h	Adjustable work surface height

Double sided Discovery™ bench module (standing height)

Modules listed above contain standard 2"x6" steel tube construction that include uprights, feet, cantilevers, bridge, leveling feet. All other components such as casters, electrical, data, and plumbing sold separately. All hardware for assembly is provided.

Note electrical and data knockouts will be provided unless specified otherwise.

Discovery™ series
Select Single and Double sided low height upright benches

These are the standard bench configurations with low height uprights going beyond the work surface. Standard widths are indicated in the sizing charts. Note these benches adjust from standing height to sitting. When they are adjusted down the electrical and data ports are exposed. Work surfaces should be cut accordingly to allow for this process unless specified. Standing height configurations can use access ports or add on upper chase assemblies for power. See accessory add section.

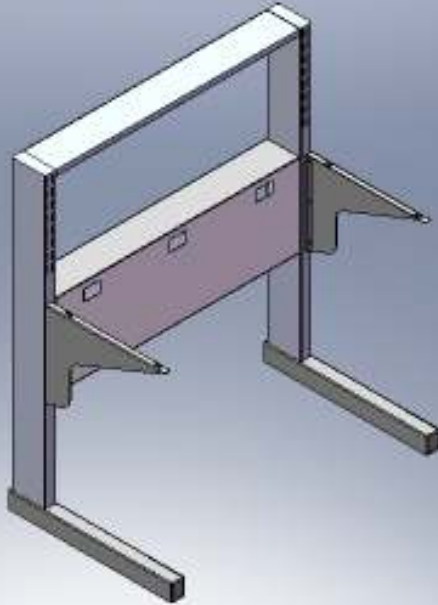

Bench Module Sizing Chart		
PART NO.	SIZE	DISC.
1SS-024-DLB-56	24"w x29"d x 56"h	Adjustable work surface height
1SS-030-DLB-56	30"w x29"d x 56"h	Adjustable work surface height
1SS-036-DLB-56	36"w x29"d x 56"h	Adjustable work surface height
1SS-042-DLB-56	42"w x29"d x 56"h	Adjustable work surface height
1SS-048-DLB-56	48"w x29"d x 56"h	Adjustable work surface height
1SS-054-DLB-56	54"w x29"d x 56"h	Adjustable work surface height
1SS-058-DLB-56	58"w x29"d x 56"h	Adjustable work surface height
1SS-060-DLB-56	60"w x29"d x 56"h	Adjustable work surface height
1SS-072-DLB-56	72"w x29"d x 56"h	Adjustable work surface height

Single sided Low height bench Discovery series bench 56"high

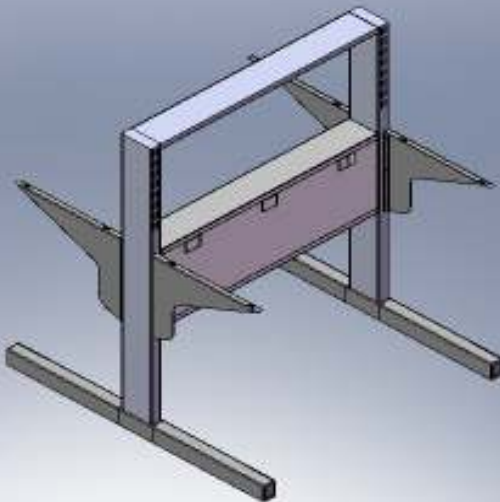

Bench Module Sizing Chart		
PART NO.	SIZE	DISC.
1DS-024-DLB-56	24"w x58"d x 56"h	Adjustable work surface height
1DS-030-DLB-56	30"w x58"d x 56"h	Adjustable work surface height
1DS-036-DLB-56	36"w x58"d x 56"h	Adjustable work surface height
1DS-042-DLB-56	42"w x58"d x 56"h	Adjustable work surface height
1DS-048-DLB-56	48"w x58"d x 56"h	Adjustable work surface height
1DS-054-DLB-56	54"w x58"d x 56"h	Adjustable work surface height
1DS-058-DLB-56	58"w x58"d x 56"h	Adjustable work surface height
1DS-060-DLB-56	60"w x58"d x 56"h	Adjustable work surface height
1DS-072-DLB-56	72"w x58"d x 56"h	Adjustable work surface height

Double sided Low height bench Discovery series bench 56"high

Modules listed above contain standard 2"x6" steel tube construction that include uprights, feet, cantilevers, bridge, leveling feet, and upper support. All other components such as shelving, casters, electrical, data, and plumbing sold separately. All hardware for assembly is provided.

Note electrical and data knockouts will be provided unless specified otherwise.

Discovery™ series Select Single and Double sided medium height upright benches

These are the standard bench configurations with medium height uprights going beyond the work surface. Standard widths are indicated in the sizing charts. Note these benches adjust from standing height to sitting. When they are adjusted down the electrical and data ports are exposed. Work surfaces should be cut accordingly to allow for this process unless specified. Standing height configurations can use access ports or add on upper chase assemblies for power. See accessory add section. **(Note when using casters do not exceed this height)**

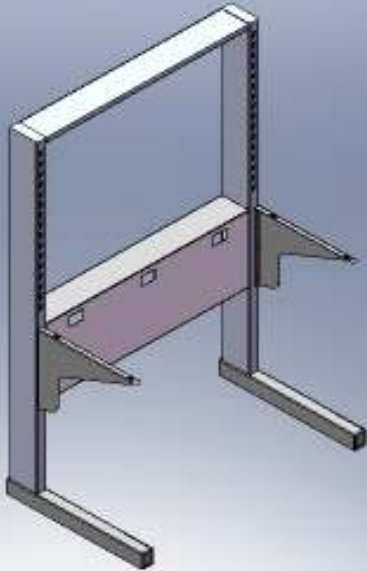

Single sided Discovery™ bench 76" high (medium height)

Bench Module Sizing Chart		
PART NO.	SIZE	DISC.
1SS-024-DLB-76	24"w x29"d x 76"h	Adjustable cantilevers & shelving
1SS-030-DLB-76	30"w x29"d x 76"h	Adjustable cantilevers & shelving
1SS-036-DLB-76	36"w x29"d x 76"h	Adjustable cantilevers & shelving
1SS-042-DLB-76	42"w x29"d x 76"h	Adjustable cantilevers & shelving
1SS-048-DLB-76	48"w x29"d x 76"h	Adjustable cantilevers & shelving
1SS-054-DLB-76	54"w x29"d x 76"h	Adjustable cantilevers & shelving
1SS-058-DLB-76	58"w x29"d x 76"h	Adjustable cantilevers & shelving
1SS-060-DLB-76	60"w x29"d x 76"h	Adjustable cantilevers & shelving
1SS-072-DLB-76	72"w x29"d x 76"h	Adjustable cantilevers & shelving

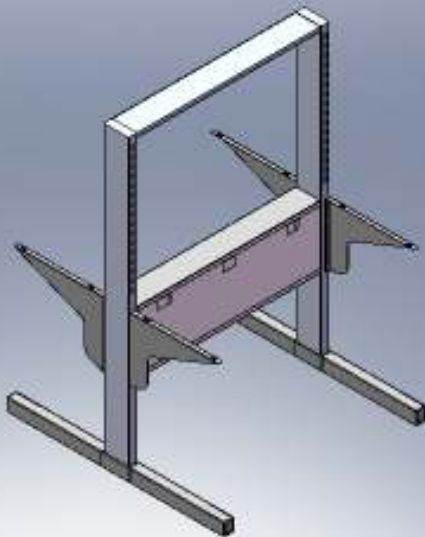

Double-sided Discovery™ bench 76" high (medium height)

Bench Module Sizing Chart		
PART NO.	SIZE	DISC.
1DS-024-DLB-76	24"w x58"d x 76"h	Adjustable cantilevers & shelving
1DS-030-DLB-76	30"w x58"d x 76"h	Adjustable cantilevers & shelving
1DS-036-DLB-76	36"w x58"d x 76"h	Adjustable cantilevers & shelving
1DS-042-DLB-76	42"w x58"d x 76"h	Adjustable cantilevers & shelving
1DS-048-DLB-76	48"w x58"d x 76"h	Adjustable cantilevers & shelving
1DS-054-DLB-76	54"w x58"d x 76"h	Adjustable cantilevers & shelving
1DS-058-DLB-76	58"w x58"d x 76"h	Adjustable cantilevers & shelving
1DS-060-DLB-76	60"w x58"d x 76"h	Adjustable cantilevers & shelving
1DS-072-DLB-76	72"w x58"d x 76"h	Adjustable cantilevers & shelving

Modules listed above contain standard 2"x6" steel tube construction that include uprights, feet, cantilevers, bridge, leveling feet, and upper support. All other components such as shelving, casters, electrical, data, and plumbing sold separately. All hardware for assembly is provided.

Note electrical and data knockouts will be provided unless specified otherwise.

Discovery™ series
Select Single and Double sided full height upright benches

These are the standard bench configurations with full height uprights going beyond the work surface. Standard widths are indicated in the sizing charts. Note these benches adjust from standing height to sitting. When they are adjusted down the electrical and data ports are exposed. Work surfaces should be cut accordingly to allow for this process unless specified. Standing height configurations can use access ports or add on upper chase assemblies for power. See accessory add section. **(Note when using casters do not exceed this height)**

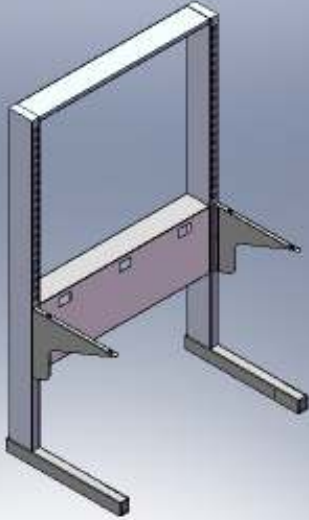

Single sided Discovery™ bench full height module 82"

Bench Module Sizing Chart		
PART NO.	SIZE	DISC.
1SS-024-DLB-82	24"w x29"d x 82"h	Adjustable cantilevers & shelving
1SS-030-DLB-82	30"w x29"d x 82"h	Adjustable cantilevers & shelving
1SS-036-DLB-82	36"w x29"d x 82"h	Adjustable cantilevers & shelving
1SS-042-DLB-82	42"w x29"d x 82"h	Adjustable cantilevers & shelving
1SS-048-DLB-82	48"w x29"d x 82"h	Adjustable cantilevers & shelving
1SS-054-DLB-82	54"w x29"d x 82"h	Adjustable cantilevers & shelving
1SS-058-DLB-82	58"w x29"d x 82"h	Adjustable cantilevers & shelving
1SS-060-DLB-82	60"w x29"d x 82"h	Adjustable cantilevers & shelving
1SS-072-DLB-82	72"w x29"d x 82"h	Adjustable cantilevers & shelving

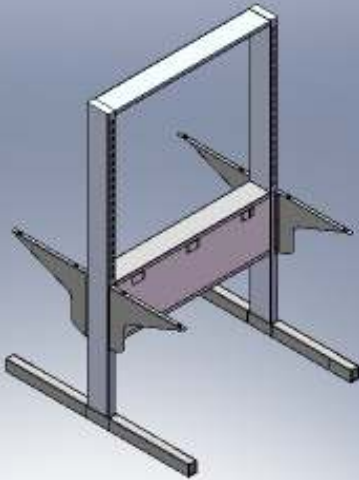

Double sided Discovery™ bench full height module 82"

Bench Module Sizing Chart		
PART NO.	SIZE	DISC.
1DS-024-DLB-82	24"w x29"d x 82"h	Adjustable cantilevers & shelving
1DS-030-DLB-82	30"w x29"d x 82"h	Adjustable cantilevers & shelving
1DS-036-DLB-82	36"w x29"d x 82"h	Adjustable cantilevers & shelving
1DS-042-DLB-82	42"w x29"d x 82"h	Adjustable cantilevers & shelving
1DS-048-DLB-82	48"w x29"d x 82"h	Adjustable cantilevers & shelving
1DS-054-DLB-82	54"w x29"d x 82"h	Adjustable cantilevers & shelving
1DS-058-DLB-82	58"w x29"d x 82"h	Adjustable cantilevers & shelving
1DS-060-DLB-82	60"w x29"d x 82"h	Adjustable cantilevers & shelving
1DS-072-DLB-82	72"w x29"d x 82"h	Adjustable cantilevers & shelving

Modules listed above contain standard 2"x6" steel tube construction that include uprights, feet, cantilevers, bridge, leveling feet, and upper support. All other components such as shelving, electrical, data, and plumbing sold separately. All hardware for assembly is provided. *Note electrical and data knockouts will be provided unless specified otherwise. Also it is not recommended to use this module with casters due to the excessive height.*

Discovery LT™ series (2"x3" framing)
Select Single and Double sided standing and sitting height benches

These are the standard bench configurations with out uprights going beyond the work surface. Standard widths are indicated in the sizing charts. Note these benches adjust from standing height to sitting. When they are adjusted down to sitting height the electrical and data ports are exposed. Work surfaces should be cut accordingly to allow for this process unless specified. Standing height configurations can use access ports or add on upper chaise assemblies for power. See accessory add section.

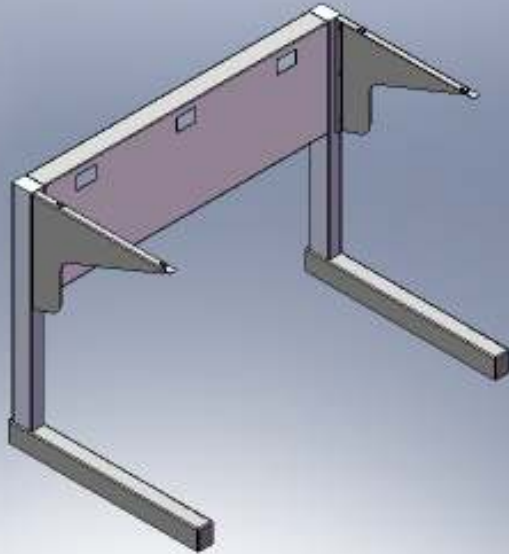

Single sided Discovery LT™ series bench modules

Bench Module Sizing Chart		
PART NO.	SIZE	DISC.
1SS-024-DLB-LT35	24"w x29"d x 35"h	Adjustable work surface height
1SS-030-DLB-LT35	30"w x29"d x 35"h	Adjustable work surface height
1SS-036-DLB-LT35	36"w x29"d x 35"h	Adjustable work surface height
1SS-042-DLB-LT35	42"w x29"d x 35"h	Adjustable work surface height
1SS-048-DLB-LT35	48"w x29"d x 35"h	Adjustable work surface height
1SS-054-DLB-LT35	54"w x29"d x 35"h	Adjustable work surface height
1SS-058-DLB-LT35	58"w x29"d x 35"h	Adjustable work surface height
1SS-060-DLB-LT35	60"w x29"d x 35"h	Adjustable work surface height
1SS-072-DLB-LT35	72"w x29"d x 35"h	Adjustable work surface height

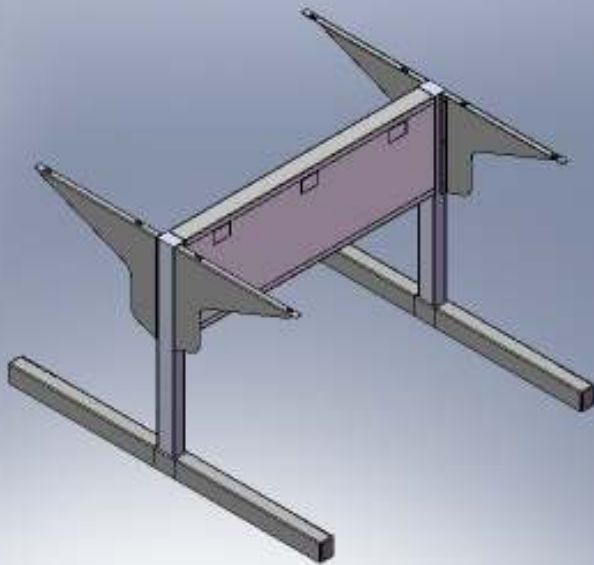

Double-sided Discovery LT™ series bench modules

Bench Module Sizing Chart		
PART NO.	SIZE	DISC.
1DS-024-DLB-LT35	24"w x58"d x 35"h	Adjustable work surface height
1DS-030-DLB-LT35	30"w x58"d x 35"h	Adjustable work surface height
1DS-036-DLB-LT35	36"w x58"d x 35"h	Adjustable work surface height
1DS-042-DLB-LT35	42"w x58"d x 35"h	Adjustable work surface height
1DS-048-DLB-LT35	48"w x58"d x 35"h	Adjustable work surface height
1DS-054-DLB-LT35	54"w x58"d x 35"h	Adjustable work surface height
1DS-058-DLB-LT35	58"w x58"d x 35"h	Adjustable work surface height
1DS-060-DLB-LT35	60"w x58"d x 35"h	Adjustable work surface height
1DS-072-DLB-LT35	72"w x58"d x 35"h	Adjustable work surface height

Modules listed above contain standard 2"x3" steel tube construction that includes: uprights, feet, cantilevers, bridge, leveling feet. All other components such as casters, electrical, data, and plumbing sold separately. All hardware for assembly is provided.

Note electrical and data knockouts will be provided unless specified otherwise.

Discovery LT™ series

Select Single and Double sided medium height upright benches

These are the standard bench configurations with medium height uprights going beyond the work surface. Standard widths are indicated in the sizing charts. Note these benches adjust from standing height to sitting. When they are adjusted down the electrical and data ports are exposed. Work surfaces should be cut accordingly to allow for this process unless specified. Standing height configurations can use access ports or add on upper chase assemblies for power. See accessory add section. **(Note when using casters do not exceed this height)**

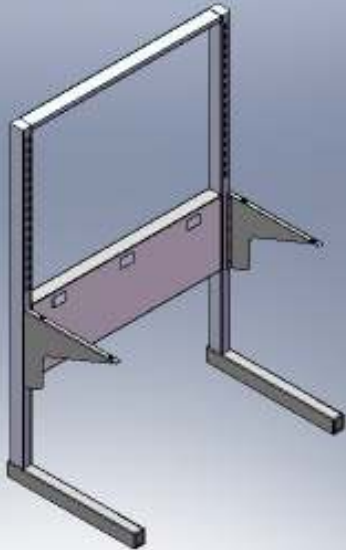

Single sided Discovery LT™ medium height module 76”h

Bench Module Sizing Chart		
PART NO.	SIZE	DISC.
1SS-024-DLB-LT76	24"w x29"d x 76"h	Adjustable cantilevers & shelving
1SS-030-DLB-LT76	30"w x29"d x 76"h	Adjustable cantilevers & shelving
1SS-036-DLB-LT76	36"w x29"d x 76"h	Adjustable cantilevers & shelving
1SS-042-DLB-LT76	42"w x29"d x 76"h	Adjustable cantilevers & shelving
1SS-048-DLB-LT76	48"w x29"d x 76"h	Adjustable cantilevers & shelving
1SS-054-DLB-LT76	54"w x29"d x 76"h	Adjustable cantilevers & shelving
1SS-058-DLB-LT76	58"w x29"d x 76"h	Adjustable cantilevers & shelving
1SS-060-DLB-LT76	60"w x29"d x 76"h	Adjustable cantilevers & shelving
1SS-072-DLB-LT76	72"w x29"d x 76"h	Adjustable cantilevers & shelving

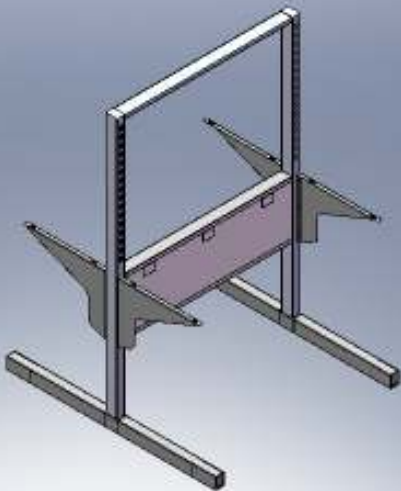

Double sided Discovery LT™ medium height module 76”h

Bench Module Sizing Chart		
PART NO.	SIZE	DISC.
1DS-024-DLB-LT76	24"w x58"d x 76"h	Adjustable cantilevers & shelving
1DS-030-DLB-LT76	30"w x58"d x 76"h	Adjustable cantilevers & shelving
1DS-036-DLB-LT76	36"w x58"d x 76"h	Adjustable cantilevers & shelving
1DS-042-DLB-LT76	42"w x58"d x 76"h	Adjustable cantilevers & shelving
1DS-048-DLB-LT76	48"w x58"d x 76"h	Adjustable cantilevers & shelving
1DS-054-DLB-LT76	54"w x58"d x 76"h	Adjustable cantilevers & shelving
1DS-058-DLB-LT76	58"w x58"d x 76"h	Adjustable cantilevers & shelving
1DS-060-DLB-LT76	60"w x58"d x 76"h	Adjustable cantilevers & shelving
1DS-072-DLB-LT76	72"w x58"d x 76"h	Adjustable cantilevers & shelving

Modules listed above contain standard 2"x6" steel tube construction that include uprights, feet, cantilevers, bridge, leveling feet, and upper support. All other components such as shelving, casters, electrical, data, and plumbing sold separately. All hardware for assembly is provided.

Note electrical and data knockouts will be provided unless specified otherwise.

Discovery LT™ series

Select Single and Double sided full height upright benches

These are the standard bench configurations with full height uprights going beyond the work surface. Standard widths are indicated in the sizing charts. Note these benches adjust from standing height to sitting. When they are adjusted down the electrical and data ports are exposed. Work surfaces should be cut accordingly to allow for this process unless specified. Standing height configurations can use access ports or add on upper chase assemblies for power. See accessory add section. **(Note when using casters do not exceed this height)**

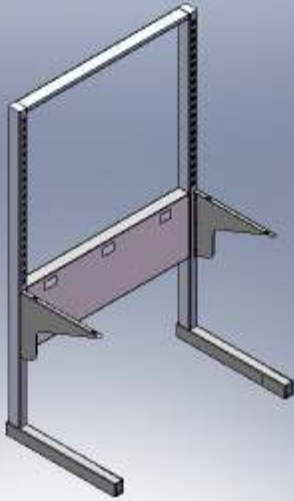

Single sided Discovery LT full height module 82”h

Bench Module Sizing Chart		
PART NO.	SIZE	DISC.
1SS-024-DLB-LT82	24" w x 29" d x 82" h	Adjustable cantilevers & shelving
1SS-030-DLB-LT82	30" w x 29" d x 82" h	Adjustable cantilevers & shelving
1SS-036-DLB-LT82	36" w x 29" d x 82" h	Adjustable cantilevers & shelving
1SS-042-DLB-LT82	42" w x 29" d x 82" h	Adjustable cantilevers & shelving
1SS-048-DLB-LT82	48" w x 29" d x 82" h	Adjustable cantilevers & shelving
1SS-054-DLB-LT82	54" w x 29" d x 82" h	Adjustable cantilevers & shelving
1SS-058-DLB-LT82	58" w x 29" d x 82" h	Adjustable cantilevers & shelving
1SS-060-DLB-LT82	60" w x 29" d x 82" h	Adjustable cantilevers & shelving
1SS-072-DLB-LT82	72" w x 29" d x 82" h	Adjustable cantilevers & shelving

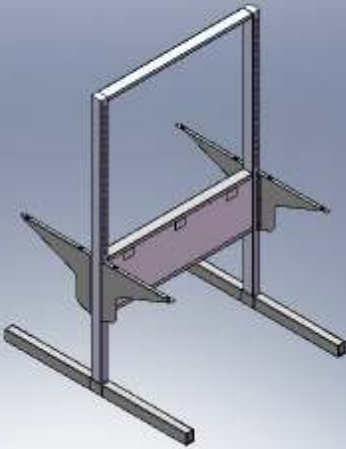

Double sided Discovery LT full height module 82”h

Bench Module Sizing Chart		
PART NO.	SIZE	DISC.
1DS-024-DLB-LT82	24" w x 29" d x 82" h	Adjustable cantilevers & shelving
1DS-030-DLB-LT82	30" w x 29" d x 82" h	Adjustable cantilevers & shelving
1DS-036-DLB-LT82	36" w x 29" d x 82" h	Adjustable cantilevers & shelving
1DS-042-DLB-LT82	42" w x 29" d x 82" h	Adjustable cantilevers & shelving
1DS-048-DLB-LT82	48" w x 29" d x 82" h	Adjustable cantilevers & shelving
1DS-054-DLB-LT82	54" w x 29" d x 82" h	Adjustable cantilevers & shelving
1DS-058-DLB-LT82	58" w x 29" d x 82" h	Adjustable cantilevers & shelving
1DS-060-DLB-LT82	60" w x 29" d x 82" h	Adjustable cantilevers & shelving
1DS-072-DLB-LT82	72" w x 29" d x 82" h	Adjustable cantilevers & shelving

Modules listed above contain standard 2"x3" steel tube construction that include uprights, feet, cantilevers, bridge, leveling feet, and upper support. All other components such as shelving, electrical, data, work surfaces, and plumbing sold separately. All hardware for assembly is provided. *Note electrical and data knockouts will be provided unless specified otherwise. Also it is not recommended to use this module with casters due to the excessive height.*

Discovery LT™ series (2"x3" framing)

Select Double sided full height island benches with floor plate mounting system

These are the standard bench configurations with uprights going beyond the work surface. Standard widths are indicated in the sizing charts. Work surfaces should be cut accordingly to allow for penetration of upright tubes. Base cabinets support work surface and also help stabilize this assembly unless using double upright configuration. Floor plates are provided with hardware for connection to uprights only. Floor mounting performed by the appropriate trades.



Discovery LT™ with floor plate mounting system (island bench application)

Floor Mount Bench Module Sizing Chart

PART NO.	SIZE	DISC.
1SU-024-FMU-86	24"w x3"d x 86"h	Bolt together assembly
1SU-030-FMU-86	30"w x3"d x 86"h	Bolt together assembly
1SU-036-FMU-86	36"w x3"d x 86"h	Bolt together assembly
1SU-042-FMU-86	42"w x3"d x 86"h	Bolt together assembly
1SU-048-FMU-86	48"w x3"d x 86"h	Bolt together assembly
1SU-054-FMU-86	54"w x3"d x 86"h	Bolt together assembly
1SU-058-FMU-86	58"w x3"d x 86"h	Bolt together assembly
1SU-060-FMU-86	60"w x3"d x 86"h	Bolt together assembly

This system comes standard with uprights, floor plates, hardware, middle and upper support brackets and channels. This system also has an option for ½ floor plates for end of run applications to keep the floor plate hidden behind a utility panel.

For shelving options see Accessories section. You can also add on power and data chases as required. Plumbing can also be run through both systems as required. Contact your dealer or representative.



Discovery LT™ stand alone floor plate mounting system
Floor plates, hardware, upper horizontal supports, and cantilevers where applicable are supplied.

Double Floor Mount Bench Module Sizing Chart

PART NO.	SIZE	DISC.
1DU-024-FMU-86	24"w x24"d x 86"h	Bolt together assembly
1DU-030-FMU-86	30"w x24"d x 86"h	Bolt together assembly
1DU-036-FMU-86	36"w x24"d x 86"h	Bolt together assembly
1DU-042-FMU-86	42"w x24"d x 86"h	Bolt together assembly
1DU-048-FMU-86	48"w x24"d x 86"h	Bolt together assembly
1DU-054-FMU-86	54"w x24"d x 86"h	Bolt together assembly
1DU-058-FMU-86	58"w x24"d x 86"h	Bolt together assembly
1DU-060-FMU-86	60"w x24"d x 86"h	Bolt together assembly

Discovery LT™ Single tube series
Select Double sided Bench Top Mounted

This system is designed to mount to the work surface off the counter top. The work surface must have a cut out (3-1/16"x2-1/16" min). It is also recommended that you do not split the tops where you penetrate for the upright. The under-mount bracing is needed to complete the assembly. One assembly includes two upright assemblies, one horizontal support, and under mount pressure plate plus hardware.



Bench top mounted Discovery LT single tube assembly shown with bottom pressure plate

Bench Surface Mount Module Sizing Chart		
PART NO.	SIZE	DISC.
1DS-024-BMU-48	24"w x3"d x 48"h	Bolt together assembly
1DS-030-BMU-48	30"w x3"d x 48"h	Bolt together assembly
1DS-036-BMU-48	36"w x3"d x 48"h	Bolt together assembly
1DS-042-BMU-48	42"w x3"d x 48"h	Bolt together assembly
1DS-048-BMU-48	48"w x3"d x 48"h	Bolt together assembly
1DS-054-BMU-48	54"w x3"d x 48"h	Bolt together assembly
1DS-058-BMU-48	58"w x3"d x 48"h	Bolt together assembly
1DS-060-BMU-48	60"w x3"d x 48"h	Bolt together assembly

Not all items shown but supplied top horizontal support, hardware, under mount pressure plate, and 2 upright slotted tube assemblies. For add on components see accessories.

EKO LT™ series (1"x3" slotted steel upright)
Select Double sided Bench Top Mounted

This system is designed to mount to the work surface off the counter top. The work surface must have drilled holes to accept mounting plate. Note the under support such as casework or other structure must be strong enough to accept the added loads of the bench and shelving plus the materials stowed. The loads will be transferred down to the work surface and casework. Use under-counter support where possible.

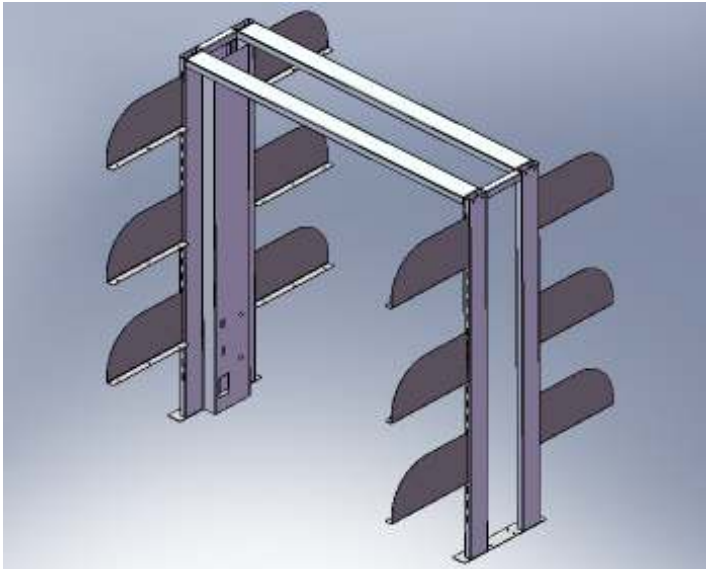

EKO LT™ series counter top mounted bench system 48"h (shown with power chase and shelf hanger brackets)

Bench Surface Mount Module Sizing Chart		
PART NO.	SIZE	DISC.
1DS-024-BSM-48	24"w x12"d x 48"h	Bolt together assembly
1DS-030-BSM-48	30"w x12"d x 48"h	Bolt together assembly
1DS-036-BSM-48	36"w x12"d x 48"h	Bolt together assembly
1DS-042-BSM-48	42"w x12"d x 48"h	Bolt together assembly
1DS-048-BSM-48	48"w x12"d x 48"h	Bolt together assembly
1DS-054-BSM-48	54"w x12"d x 48"h	Bolt together assembly
1DS-058-BSM-48	58"w x12"d x 48"h	Bolt together assembly
1DS-060-BSM-48	60"w x12"d x 48"h	Bolt together assembly

**Discovery LT™ series (2"x3" Fixed H-LEG framing) Casework suspended system
Select Single and Double sided standing and sitting height benches**

These are the standard bench configurations with outrights going beyond the work surface. Standard widths are indicated in the sizing charts. Note these benches are fixed standing height or sitting (specify). When they are adjusted down to sitting height the electrical and data ports are exposed. Work surfaces should be cut accordingly to allow for this process unless specified. Standing height configurations can use access ports or add on upper chase assemblies for power. See accessory add section. (Recommended for heavy or medium load applications)

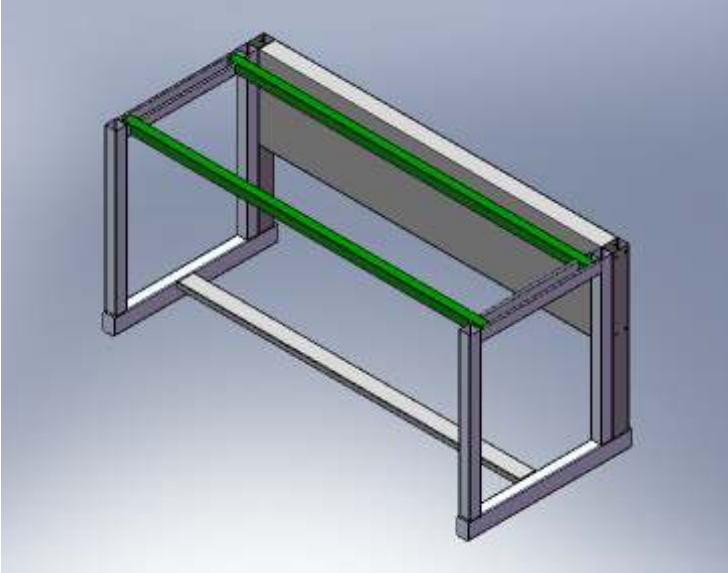

Bench "H" Leg Module Sizing Chart		
PART NO.	SIZE	DISC.
1HS-024-DLB-LT35	24"w x29"d x 35"h	Fixed work surface height
1HS-030-DLB-LT35	30"w x29"d x 35"h	Fixed work surface height
1HS-036-DLB-LT35	36"w x29"d x 35"h	Fixed work surface height
1HS-042-DLB-LT35	42"w x29"d x 35"h	Fixed work surface height
1HS-048-DLB-LT35	48"w x29"d x 35"h	Fixed work surface height
1HS-054-DLB-LT35	54"w x29"d x 35"h	Fixed work surface height
1HS-058-DLB-LT35	58"w x29"d x 35"h	Fixed work surface height
1HS-060-DLB-LT35	60"w x29"d x 35"h	Fixed work surface height
1HS-072-DLB-LT35	72"w x29"d x 35"h	Fixed work surface height

Discovery LT™ Bench modules "H" leg design UNISTRUT® for suspended casework Single Sided

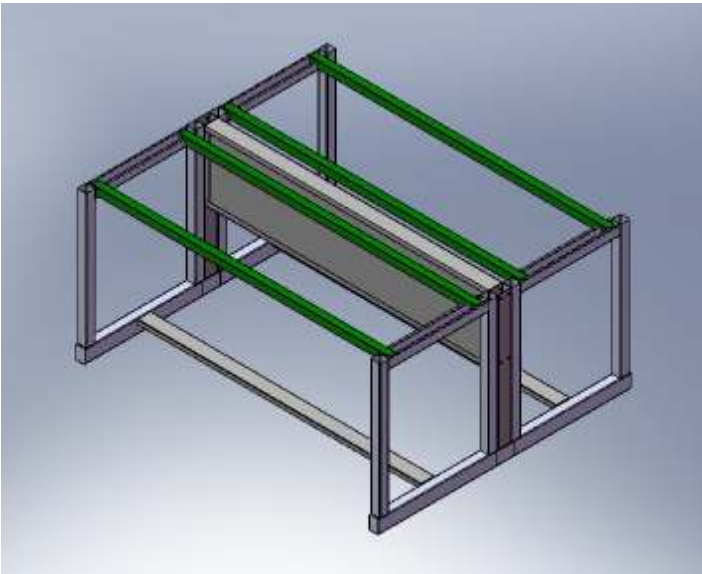

Bench "H" Leg Module Sizing Chart		
PART NO.	SIZE	DISC.
1HD-024-DLB-LT35	24"w x58"d x 35"h	Fixed work surface height
1HD-030-DLB-LT35	30"w x58"d x 35"h	Fixed work surface height
1HD-036-DLB-LT35	36"w x58"d x 35"h	Fixed work surface height
1HD-042-DLB-LT35	42"w x58"d x 35"h	Fixed work surface height
1HD-048-DLB-LT35	48"w x58"d x 35"h	Fixed work surface height
1HD-054-DLB-LT35	54"w x58"d x 35"h	Fixed work surface height
1HD-058-DLB-LT35	58"w x58"d x 35"h	Fixed work surface height
1HD-060-DLB-LT35	60"w x58"d x 35"h	Fixed work surface height
1HD-072-DLB-LT35	72"w x58"d x 35"h	Fixed work surface height

Discovery LT™ Bench modules "H" leg design UNISTRUT® for suspended casework Double Sided

Modules listed above contain standard 2"x3" & 2"x2" steel tube construction that include uprights, feet, horizontal support, bridge, leveling feet, & Unistrut®. All other components such as casters, electrical, data, work surfaces, and plumbing sold separately. All hardware for assembly is provided.

Note electrical and data knockouts will not be provided unless specified.

**Discovery LT™ series (2"x3" Fixed H-LEG framing) Casework suspended system
Select Single and Double sided medium height benches**

These are the standard bench configurations with uprights going beyond the work surface. Standard widths are indicated in the sizing charts. Note these benches are fixed standing height or sitting (specify). When they are adjusted down to sitting height the electrical and data ports are exposed. Work surfaces should be cut accordingly to allow for this process unless specified. Standing height configurations can use access ports or add on upper chase assemblies for power. See accessory add section. (Recommended for heavy or medium load applications)

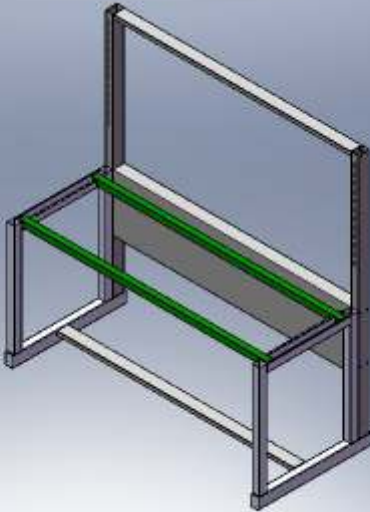

Bench "H" Leg Module Sizing Chart		
PART NO.	SIZE	DISC.
1HS-024-DLB-LT76	24"w x29"d x 76"h	Fixed work surface height
1HS-030-DLB-LT76	30"w x29"d x 76"h	Fixed work surface height
1HS-036-DLB-LT76	36"w x29"d x 76"h	Fixed work surface height
1HS-042-DLB-LT76	42"w x29"d x 76"h	Fixed work surface height
1HS-048-DLB-LT76	48"w x29"d x 76"h	Fixed work surface height
1HS-054-DLB-LT76	54"w x29"d x 76"h	Fixed work surface height
1HS-058-DLB-LT76	58"w x29"d x 76"h	Fixed work surface height
1HS-060-DLB-LT76	60"w x29"d x 76"h	Fixed work surface height
1HS-072-DLB-LT76	72"w x29"d x 76"h	Fixed work surface height

Discovery LT™ "H" leg single sided assembly with 76" h slotted uprights

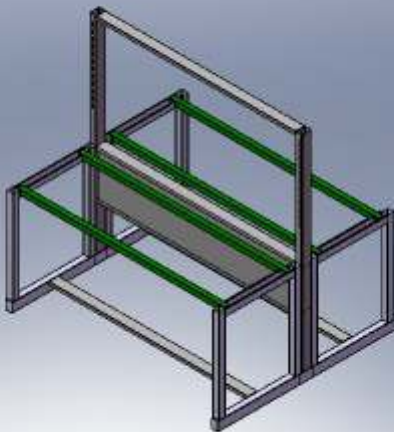

Bench "H" Leg Module Sizing Chart		
PART NO.	SIZE	DISC.
1HD-024-DLB-LT76	24"w x58"d x 76"h	Fixed work surface height
1HD-030-DLB-LT76	30"w x58"d x 76"h	Fixed work surface height
1HD-036-DLB-LT76	36"w x58"d x 76"h	Fixed work surface height
1HD-042-DLB-LT76	42"w x58"d x 76"h	Fixed work surface height
1HD-048-DLB-LT76	48"w x58"d x 76"h	Fixed work surface height
1HD-054-DLB-LT76	54"w x58"d x 76"h	Fixed work surface height
1HD-058-DLB-LT76	58"w x58"d x 76"h	Fixed work surface height
1HD-060-DLB-LT76	60"w x58"d x 76"h	Fixed work surface height
1HD-072-DLB-LT76	72"w x58"d x 76"h	Fixed work surface height

Discovery LT™ "H" leg double sided assembly with 76" h slotted uprights

Modules listed above contain standard 2"x3" & 2"x2" steel tube construction that include slotted uprights, feet, horizontal support, bridge, leveling feet & Unistrut®. All other components such as casters, electrical, data, work surfaces, and plumbing sold separately. All hardware for assembly is provided.

Note electrical and data knockouts will not be provided unless specified.

**Discovery LT™ series (2"x3" Fixed H-LEG framing) Casework suspended system
Select Single and Double sided medium height benches**

These are the standard bench configurations with uprights going beyond the work surface. Standard widths are indicated in the sizing charts. Note these benches are fixed standing height or sitting (specify). When they are adjusted down to sitting height the electrical and data ports are exposed. Work surfaces should be cut accordingly to allow for this process unless specified. Standing height configurations can use access ports or add on upper chase assemblies for power. See accessory add section.
(Recommended for heavy or medium load applications)

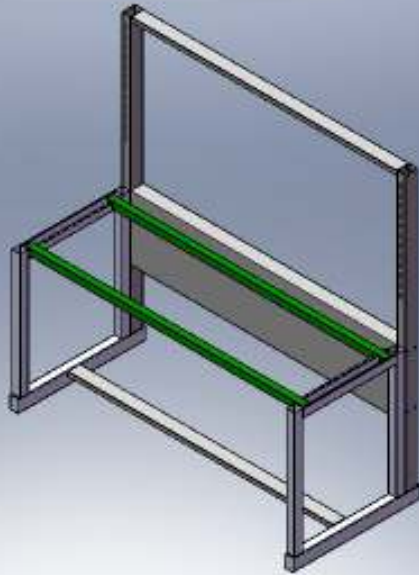

Bench "H" Leg Module Sizing Chart		
PART NO.	SIZE	DISC.
1HS-024-DLB-LT82	24"w x29"d x 82"h	Fixed work surface height
1HS-030-DLB-LT82	30"w x29"d x 82"h	Fixed work surface height
1HS-036-DLB-LT82	36"w x29"d x 82"h	Fixed work surface height
1HS-042-DLB-LT82	42"w x29"d x 82"h	Fixed work surface height
1HS-048-DLB-LT82	48"w x29"d x 82"h	Fixed work surface height
1HS-054-DLB-LT82	54"w x29"d x 82"h	Fixed work surface height
1HS-058-DLB-LT82	58"w x29"d x 82"h	Fixed work surface height
1HS-060-DLB-LT82	60"w x29"d x 82"h	Fixed work surface height
1HS-072-DLB-LT82	72"w x29"d x 82"h	Fixed work surface height

Discovery LT™ "H" leg single sided assembly with 82" h full height slotted uprights

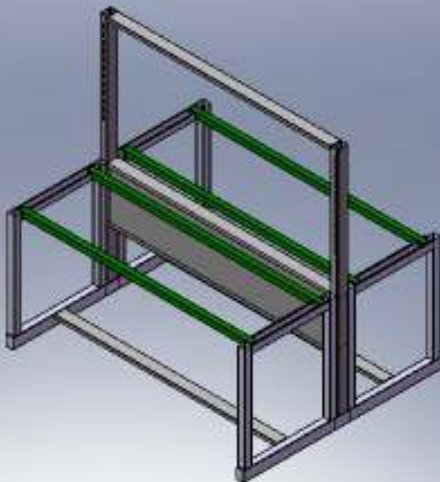

Bench "H" Leg Module Sizing Chart		
PART NO.	SIZE	DISC.
1HD-024-DLB-LT82	24"w x58"d x 82"h	Fixed work surface height
1HD-030-DLB-LT82	30"w x58"d x 82"h	Fixed work surface height
1HD-036-DLB-LT82	36"w x58"d x 82"h	Fixed work surface height
1HD-042-DLB-LT82	42"w x58"d x 82"h	Fixed work surface height
1HD-048-DLB-LT82	48"w x58"d x 82"h	Fixed work surface height
1HD-054-DLB-LT82	54"w x58"d x 82"h	Fixed work surface height
1HD-058-DLB-LT82	58"w x58"d x 82"h	Fixed work surface height
1HD-060-DLB-LT82	60"w x58"d x 82"h	Fixed work surface height
1HD-072-DLB-LT82	72"w x58"d x 82"h	Fixed work surface height

Discovery LT™ "H" leg double sided assembly with 82" h full height slotted uprights

Modules listed above contain standard 2"x3" & 2"x2" steel tube construction that include slotted uprights, horizontal support, feet, bridge, leveling feet & Unistrut®. All other components such as casters, work surfaces, electrical, data, and plumbing sold separately. All hardware for assembly is provided.
Note electrical and data knockouts will not be provided unless specified.

Double sided Center Island benches Discovery™ series (Fixed Floor mounted system) Use with Tables or separate benches

These are the standard island configurations with uprights not going beyond the work surface. Standard widths are indicated in the sizing charts. Note these benches are fixed height or sitting (specify). When the benches or tables set next to the system are sitting height the electrical and data ports are exposed. Work surfaces should be cut accordingly to allow for this process unless specified. Standing height configurations can use access ports or add on upper chase assemblies for power. See accessory add section in this catalog.

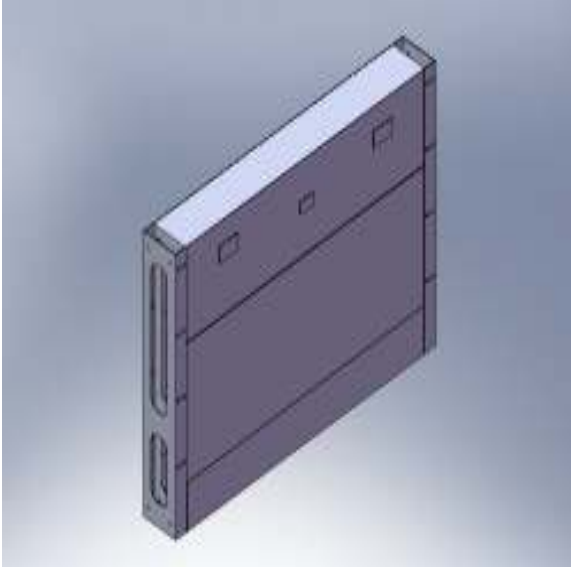

Island Floor mounted Discovery™ Bench System 36”h
(Power, data, and plumbing delivery system)

Floor Mount Island Bench Module Sizing Chart		
PART NO.	SIZE	DISC.
1SU-024-FMI-36	24"w x3"d x 36"h	Bolt together assembly
1SU-030-FMI-36	30"w x3"d x 36"h	Bolt together assembly
1SU-036-FMI-36	36"w x3"d x 36"h	Bolt together assembly
1SU-042-FMI-36	42"w x3"d x 36"h	Bolt together assembly
1SU-048-FMI-36	48"w x3"d x 36"h	Bolt together assembly
1SU-054-FMI-36	54"w x3"d x 36"h	Bolt together assembly
1SU-058-FMI-36	58"w x3"d x 36"h	Bolt together assembly
1SU-060-FMI-36	60"w x3"d x 36"h	Bolt together assembly

The 6” deep system is shown we also offer a 12” and 24” deep base system as well. You can mount cantilevers and casework from these modules.

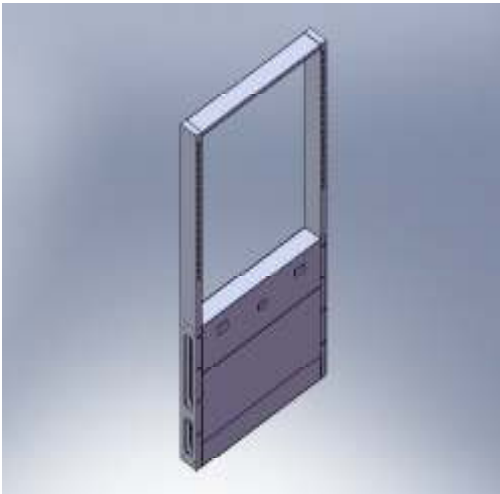

Island Floor mounted Discovery™ Bench System 82”h
(Power, data, and plumbing delivery system)

Floor Mount Island Bench Module Sizing Chart		
PART NO.	SIZE	DISC.
1SU-024-FMI-86	24"w x3"d x 86"h	Bolt together assembly
1SU-030-FMI-86	30"w x3"d x 86"h	Bolt together assembly
1SU-036-FMI-86	36"w x3"d x 86"h	Bolt together assembly
1SU-042-FMI-86	42"w x3"d x 86"h	Bolt together assembly
1SU-048-FMI-86	48"w x3"d x 86"h	Bolt together assembly
1SU-054-FMI-86	54"w x3"d x 86"h	Bolt together assembly
1SU-058-FMI-86	58"w x3"d x 86"h	Bolt together assembly
1SU-060-FMI-86	60"w x3"d x 86"h	Bolt together assembly

Modules listed above contain standard 2”x6” steel tube construction that include slotted uprights, filler panels, “c” bridge, Upper horizontal support, and floor mounting plate with supports. All other components such as shelving, cantilevers, electrical, data, and plumbing sold separately. All hardware for assembly is provided except floor-mounting hardware.

Note electrical and data knockouts will be provided unless specified 4 electrical and 2 data.

**Single sided benches EKO™ series
(Fixed and mobile tables with Bolt on uprights)**

These are the standard table bench type system with adjustable height legs. The construction is a 2"x2" tube steel frame and upright. This system is sold in both steel and 304 stainless steel as required to meet customer needs. This can also be used for ADA applications as required. Adjustment ranges are from 30" to 40" high.

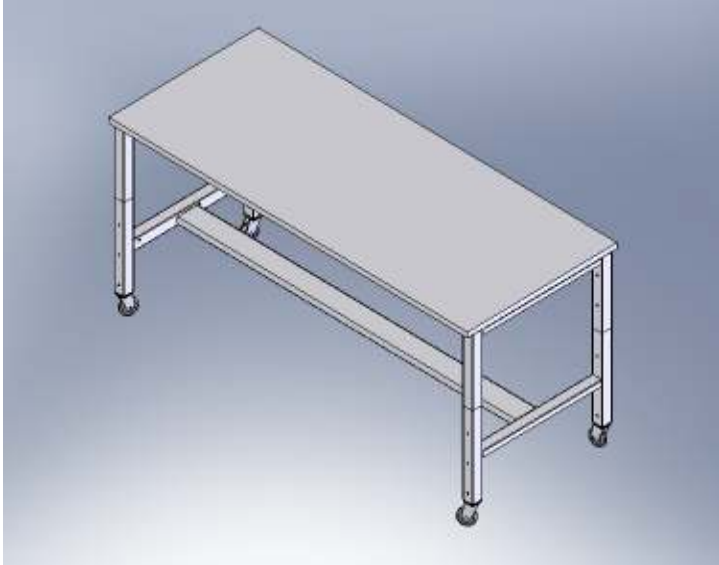

Bench Adjustable Height Module Chart		
PART NO.	SIZE	DISC.
1HS-024-ELB-A35	24"w x28"d x 35"h	Adj. work surface height
1HS-030-ELB-A35	30"w x28"d x 35"h	Adj. work surface height
1HS-036-ELB-A35	36"w x28"d x 35"h	Adj. work surface height
1HS-042-ELB-A35	42"w x28"d x 35"h	Adj. work surface height
1HS-048-ELB-A35	48"w x28"d x 35"h	Adj. work surface height
1HS-054-ELB-A35	54"w x28"d x 35"h	Adj. work surface height
1HS-058-ELB-A35	58"w x28"d x 35"h	Adj. work surface height
1HS-060-ELB-A35	60"w x28"d x 35"h	Adj. work surface height
1HS-072-ELB-A35	72"w x28"d x 35"h	Adj. work surface height

EKO Bench and table configurations with adjustable legs and casters shown (leveling feet standard)

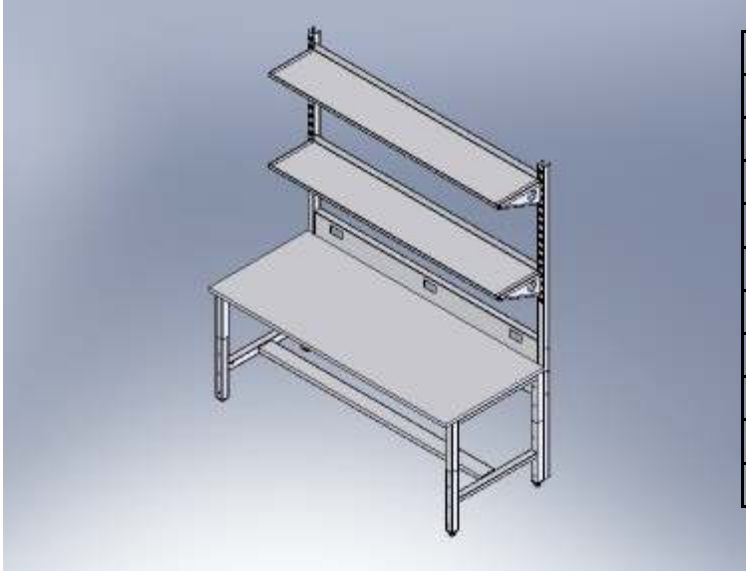

Bench Adjustable Height Module Chart		
PART NO.	SIZE	DISC.
1HS-024-ELB-A82	24"w x30"d x 82"h	Adj. work surface height
1HS-030-ELB-A82	30"w x30"d x 82"h	Adj. work surface height
1HS-036-ELB-A82	36"w x30"d x 82"h	Adj. work surface height
1HS-042-ELB-A82	42"w x30"d x 82"h	Adj. work surface height
1HS-048-ELB-A82	48"w x30"d x 82"h	Adj. work surface height
1HS-054-ELB-A82	54"w x30"d x 82"h	Adj. work surface height
1HS-058-ELB-A82	58"w x30"d x 82"h	Adj. work surface height
1HS-060-ELB-A82	60"w x30"d x 82"h	Adj. work surface height
1HS-072-ELB-A82	72"w x30"d x 82"h	Adj. work surface height

EKO Bench with full height uprights, power bridge assembly, and flat shelves

Modules listed above contain standard 2"x2" steel tube construction that include slotted uprights, horizontal support, feet, bridge, leveling feet. All other components such as casters, shelving, electrical, data, work surfaces, and plumbing sold separately. All hardware for assembly is provided.

Note electrical and data knockouts will be provided unless specified.

Tables EKO™ series (Fixed and mobile tables)

These are the standard table bench type system with adjustable height legs. The construction is a 2"x2" tube steel frame and upright. This system is sold in both steel and 304 stainless steel as required to meet customer needs. This can also be used for ADA applications as required. Adjustment ranges are from 30" to 40" high. This can also be configured for economical student tables. All height adjustment is manual. An ADA power or hand crank lift system is sold with the Discovery style Bench system.

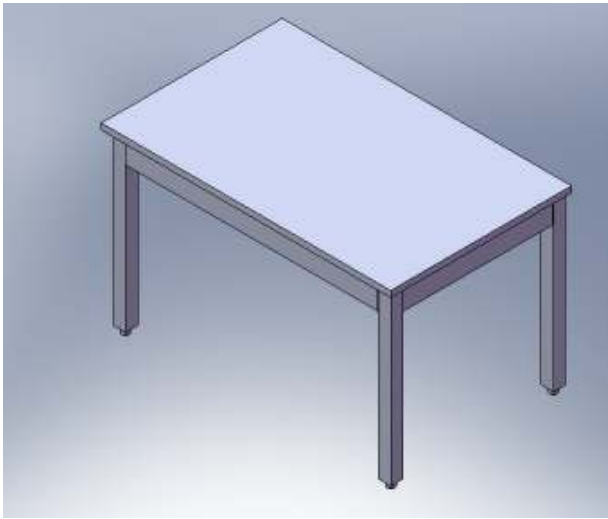

Table Adjustable Height Module Chart		
PART NO.	SIZE	DISC.
1ET-024-ELB	24"w x28"d x 35"h	Adj. work surface height
1ET-030-ELB	30"w x28"d x 35"h	Adj. work surface height
1ET-036-ELB	36"w x28"d x 35"h	Adj. work surface height
1ET-042-ELB	42"w x28"d x 35"h	Adj. work surface height
1ET-048-ELB	48"w x28"d x 35"h	Adj. work surface height
1ET-054-ELB	54"w x28"d x 35"h	Adj. work surface height
1ET-058-ELB	58"w x28"d x 35"h	Adj. work surface height
1ET-060-ELB	60"w x28"d x 35"h	Adj. work surface height
1ET-072-ELB	72"w x28"d x 35"h	Adj. work surface height

Student Table Euro™ series (Fixed and mobile tables)

These are the standard table bench type system with adjustable height legs. The construction is a 2"x2" and 2"x10" tube steel frame and upright. This system is sold in both steel and 304 stainless steel as required to meet customer needs. This can also be used for ADA applications as required. Adjustment ranges are from 30" to 40" high. 120v. system with 9' power cord when using the power system.



Student power lift table

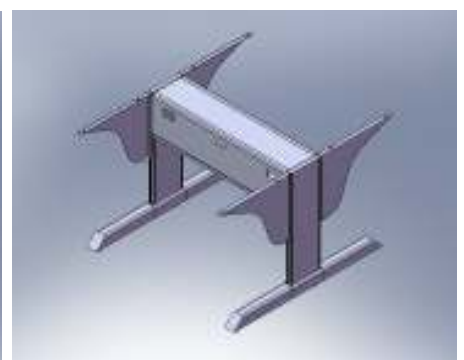
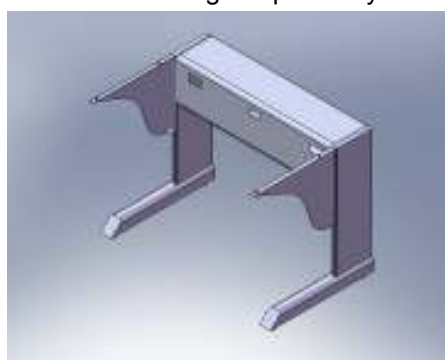

These benches can also be used for ADA compliant applications (Vision series benches)

Student tables are configured to maximize classroom space. Work surfaces, power, and data connections are added features. The hand crank system uses a similar configuration.



Special application type Test Bench shown

Custom built systems are available with a quick turn around...

Special designs and specific applications:

We currently run design specific products for many different industries including electronics. We offer ESD compliant furniture systems as well that are not shown in this catalog.

This bench is an example of design formulated and built within days and shipped within three weeks. We typically can design and build your system in a very timely manner and stay within your budget as well. For more details contact your dealer or representative.

ACCESSORY ADD COMPONENTS

Floating Bridge Connector Double Sided:

Discovery Bench System – DS or Double Sided Cut Outs for Power and Data and plumbing. Floating Bridge Horizontal Connector Double sided for above work surfaces. If data is needed

For any of the configurations add –(D) at the very end of the part number.

For REAGENT shelf add “R” at the end of your part number. Note all LT versions are 3” deep just follow part number with -LT.

FLOATING BRIDGE HORIZONTAL DS SELECTION CHART

PART NO.	DISCRIPTION	SIZE DxWxH
006-022-DSF	Connector w/o electrical c/o or plumbing or data	6"x22"x7"
006-028-DSF	Connector w/o electrical c/o or plumbing or data	6"x28"x7"
006-034-DSF	Connector w/o electrical c/o or plumbing or data	6"x34"x7"
006-040-DSF	Connector w/o electrical c/o or plumbing or data	6"x40"x7"
006-046-DSF	Connector w/o electrical c/o or plumbing or data	6"x46"x7"
006-058-DSF	Connector w/o electrical c/o or plumbing or data	6"x58"x7"

FLOATING BRIDGE HORIZONTAL DS W/ POWER SELECTION CHART

PART NO.	DISCRIPTION	SIZE DxWxH
006-022-DSF-P	Connector w/ 2 electrical duplex w/o plumbing	6"x22"x7"
006-028-DSF-P	Connector w/ 2 electrical duplex w/o plumbing	6"x28"x7"
006-034-DSF-P	Connector w/ 2 electrical duplex w/o plumbing	6"x34"x7"
006-040-DSF-P	Connector w/ 2 electrical duplex w/o plumbing	6"x40"x7"
006-046-DSF-P	Connector w/ 2 electrical duplex w/o plumbing	6"x46"x7"
006-058-DSF-P	Connector w/ 2 electrical duplex w/o plumbing	6"x58"x7"

For more duplex outlets add number after P such as 006-022-DSF-P4

FLOATING BRIDGE HORIZONTAL DS W/ POWER AND PLUMBING SELECTION CHART

PART NO.	DISCRIPTION	SIZE DxWxH
006-022-DSF-PP	Connector w/o data with c/o 4 dup. and 2 cutout plumbing	6"x22"x7"
006-028-DSF-PP	Connector w/o data with c/o 4 dup. and 2 cutout plumbing	6"x28"x7"
006-034-DSF-PP	Connector w/o data with c/o 4 dup. and 2 cutout plumbing	6"x34"x7"
006-040-DSF-PP	Connector w/o data with c/o 4 dup. and 2 cutout plumbing	6"x40"x7"
006-046-DSF-PP	Connector w/o data with c/o 4 dup. and 2 cutout plumbing	6"x46"x7"
006-058-DSF-PP	Connector w/o data with c/o 4 dup. and 2 cutout plumbing	6"x58"x7"

Note: Add 5 to the first # prefix indicates component to be type 304-stainless steel with a number 4 finish. For example 006-028-DSF becomes 506-028-DSF for stainless steel.

Also for both power and data cut outs add PD to the end of the size indicated. For more then

The pictured number of cutouts adds PDS to the end and submit number of data and outlets needed. For vertical chase connection indicate the width size only like –PDS6, or 6” wide chase.

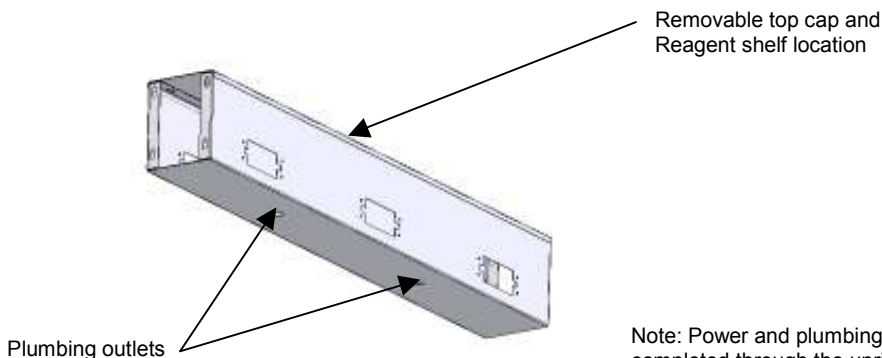

Note: Power and plumbing access into ceiling or floor is completed through the uprights or typically through add on pipe chase assemblies up or down. Floating bridges are cutout accordingly to match up with the uprights pierced locations. Also you can add a Reagent shelf to the top of the bridge if needed.

Cantilevers:

Bench System –

Cantilever – Steel support brackets used to carry work surfaces and casework as needed.

Left and Right Selection guide – Note heavy-duty cantilevers with tube are also set up to handle under mount casework. Specify by adding a “U” after the part number if suspending casework.

Note: The 5 prefix indicates component to be type 304-stainless steel with a number 4 finish.

HANDED CANTILEVER SELECTION CHART

PART NO.	DISCRIPTION	SIZE WxDxH
006-023-SCB-RH	Cantilever RH mounted standard duty	1"x24"x23"
006-029-SCB-RH	Cantilever RH mounted standard duty	1"x24"x29"
006-035-SCB-RH	Cantilever RH mounted standard duty	1"x24"x35"
006-023-HCB-RH	Cantilever RH mounted heavy duty w/ supt. Tube	1"x24"x23"
006-029-HCB-RH	Cantilever RH mounted heavy duty w/ supt. Tube	1"x29"x29"
006-023-SCB-LH	Cantilever LH mounted standard duty	1"x24"x23"
006-029-SCB-LH	Cantilever LH mounted standard duty	1"x24"x29"
006-035-SCB-LH	Cantilever LH mounted standard duty	1"x24"x35"
006-023-HCB-LH	Cantilever LH mounted heavy duty w/ supt. Tube	1"x24"x23"
006-029-HCB-LH	Cantilever LH mounted heavy duty w/ supt. Tube	1"x29"x29"

Standard cantilever simply bolts on to the upright in various seated and standing positions. Use for all versions of bench series.

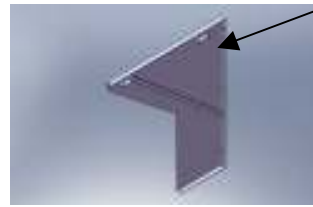
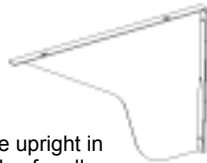

Insert slots for under mount casework Channels, see kit sizes

The HD cantilever is set up to provide support members for under mount cabinets. This same cantilever can also be used when heavy devices will be placed on the work surface supported by cantilevers.

Vertical Chase:

The vertical chase is screwed to the vertical uprights either to the ceiling or to the floor. The chases carry or segregate plumbing, electrical, & data. Each chase has an access panel for easy installation and up keep. Use LT in part number example LT5-028-VUC (All LT versions 3" deep)

Discovery Bench System – Utility Vertical Chase with Covers (Use same part number below for LT but add –LT to end of part number)

VERTICAL CHASE SELECTION CHART (For LT use LT5- to start part number)

PART NO.	DISCRIPTION	SIZE WxDxH
006-028-VUC	Ceiling to upright top – set for 10' height 4" wide	4"x6"x28"
006-028-VUC-6	Ceiling to upright top – set for 10' height 6" wide	6"x6"x28"
006-028-VUC-8	Ceiling to upright top – set for 10' height 8" wide	8"x6"x28"
006-028-VUC-10	Ceiling to upright top – set for 10' height 10" wide	10"x6"x28"
006-028-VUC-12	Ceiling to upright top – set for 10' height 12" wide	12"x6"x28"

Note: Add 5 to the first # prefix indicates component to be type 304-stainless steel with a number 4 finish. For example 006-028-VUC becomes 506-028-VUC for stainless steel. Also remember to add an alternate width just add it to the end of the part number like 006-022-VUC-7 (7" wide utility chase 22" high). If power or data outlets are needed specify.

All vertical enclosures have access panels for easy installation and upkeep. Panels are easy to remove and replace.



The enclosure runs the length of the upright. There are extensions for continued penetration into the drop ceiling space. Also separate walls can be added for segregated utilities.

The depth of the enclosure varies based on how much data, power, and plumbing needed. The enclosure can be modified to any depth needed.

Casters and Leveling Feet:

The casters are an NSF approved type ranging from standard duty rated at 200lbs per caster. The next step up is rated for medium duty with a rating of 300 to 400lbs per caster. And the heavy duty caster rated for 1,000lbs per caster. All casters are locking and non-locking type with non-skidding wheels. Special sealed bearings and other materials can be specified just contact your local dealer or representative.

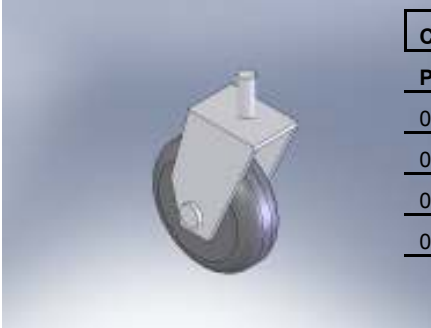

Locking and non-locking swivel typical

CASTERS STANDARD AND HEAVY DUTY		
PART NO.	DISCRIPTION (Standard duty 250lbs per caster)	COLOR
006-003-SDC	Caster standard duty 3" wheel (sold in sets of 4)	BLACK
006-004-SDC	Caster standard duty 4" wheel	GRAY
006-005-SDC	Caster standard duty 5" wheel	GRAY
006-006-HDC	Caster heavy duty 5" wheel	BLACK
	Heavy duty caster 800 lbs per caster	

Leveling Feet:

The leveling feet are a nickel plated or stainless steel construction with a non marking neoprene pad. The loads are rated for each leveling pad.

Note for seismic conditions we also provide a pad with a plate for easy floor attachment.



Adjustable height leveling pads

LEVELING PADS FOR STANDARD, SIESMIC, AND VIBRATION CONTROL		
PART NO.	DISCRIPTION (Standard duty 1,200lbs per leveling pad)	COLOR
006-001-SLF	Standard duty leveling pad non marking neoprene	BLACK
SM6-001-SLF	Seismic control type leveling foot pad	BLACK
VC6-001-SLF	Vibration control leveling foot non-marking	BLACK
006-002-SLF	Economical leveling pad non marking neoprene	BLACK
	<i>All are made from either stainless steel or plated steel</i>	

DATA:

Our typical data ports are cut out to receive a Panduit® style connector that allows for up to four connections. We are not limited to supplying just Panduit® type products if there is a specific manufacture you use will typically make adjustments for that product. We only offer receptacle installation all other or final installation by appropriate trades. When ordering your system just specify what product you would prefer.

Colors: -W = White, -B = Black, -G = Gray, and -S = Sand (snap in covers are offered to seal off)

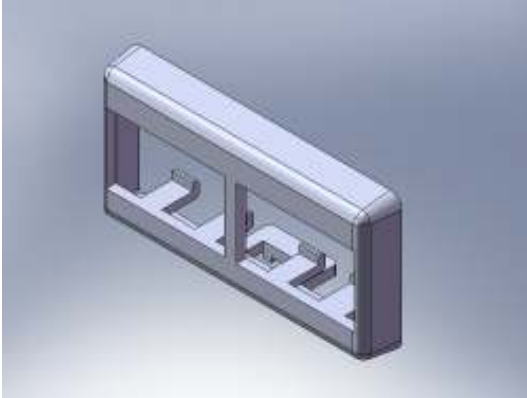

Part #101-003-002-G Shown without J45 Connectors

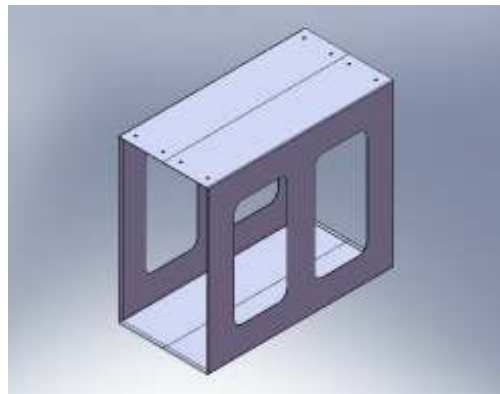

Under mount PC carrier steel with a powder coat finish to match bench #101-010-CPU

Power Chase Horizontal:

The horizontal chase is mounted to the top of the “c” bridge used to hold the uprights together. The horizontal chase allows for data and power outlets above the standing height work surface. For greater details see below. Also note for 3” deep LT version use LT6-022-HPC for example.

Discovery & Discovery LT Bench System – Horizontal Power Chase (Add –LT to part number)

HORIZONTAL POWER CHASE SELECTION CHART

PART NO.	DISCRIPTION	SIZE WxDxH
006-022-HPC	Horizontal Power Chase w/o electrical c/o or data	6"x22"x6"
006-028-HPC	Horizontal Power Chase w/o electrical c/o or data	6"x28"x6"
006-034-HPC	Horizontal Power Chase w/o electrical c/o or data	6"x34"x6"
006-040-HPC	Horizontal Power Chase w/o electrical c/o or data	6"x40"x6"
006-046-HPC	Horizontal Power Chase w/o electrical c/o or data	6"x46"x6"
006-058-HPC	Horizontal Power Chase w/o electrical c/o or data	6"x58"x6"

HORIZONTAL POWER CHASE w/ DATA SELECTION CHART

PART NO.	DISCRIPTION	SIZE WxDxH
006-022-HPC-D	Horizontal Power Chase w/ data c/o one is std. centered	6"x22"x6"
006-028-HPC-D	Horizontal Power Chase w/ data c/o one is std. centered	6"x28"x6"
006-034-HPC-D	Horizontal Power Chase w/ data c/o one is std. centered	6"x34"x6"
006-040-HPC-D	Horizontal Power Chase w/ data c/o one is std. centered	6"x40"x6"
006-046-HPC-D	Horizontal Power Chase w/ data c/o one is std. centered	6"x46"x6"
006-058-HPC-D	Horizontal Power Chase w/ data c/o one is std. centered	6"x58"x6"

HORIZONTAL POWER CHASE w/ POWER SELECTION CHART

PART NO.	DISCRIPTION	SIZE WxDxH
006-022-HPC-P	Horizontal Power Chase w/ electrical c/o 2 dup std.	6"x22"x6"
006-028-HPC-P	Horizontal Power Chase w/ electrical c/o 2 dup std.	6"x28"x6"
006-034-HPC-P	Horizontal Power Chase w/ electrical c/o 2 dup std.	6"x34"x6"
006-040-HPC-P	Horizontal Power Chase w/ electrical c/o 2 dup std.	6"x40"x6"
006-046-HPC-P	Horizontal Power Chase w/ electrical c/o 2 dup std.	6"x46"x6"
006-058-HPC-P	Horizontal Power Chase w/ electrical c/o 2 dup std.	6"x58"x6"

HORIZONTAL POWER CHASE w/ POWER SELECTION CHART

PART NO.	DISCRIPTION	SIZE WxDxH
006-022-HPC-PD	Horizontal Power Chase w/ electrical c/o 2 dup & 1 data	6"x22"x6"
006-028-HPC-PD	Horizontal Power Chase w/ electrical c/o 2 dup & 1 data	6"x28"x6"
006-034-HPC-PD	Horizontal Power Chase w/ electrical c/o 2 dup & 1 data	6"x34"x6"
006-040-HPC-PD	Horizontal Power Chase w/ electrical c/o 2 dup & 1 data	6"x40"x6"
006-046-HPC-PD	Horizontal Power Chase w/ electrical c/o 2 dup & 1 data	6"x46"x6"
006-058-HPC-PD	Horizontal Power Chase w/ electrical c/o 2 dup & 1 data	6"x58"x6"

Note: Add 5 to the first # prefix indicates component to be type 304-stainless steel with a number 4 finish. For example 006-028-HPC becomes 506-028-HPC for stainless steel. For more then the pictured number of cutouts add S to the end and submit number of data and power outlets needed. For vertical chase connection indicate LH or RH utility run and chase width size.

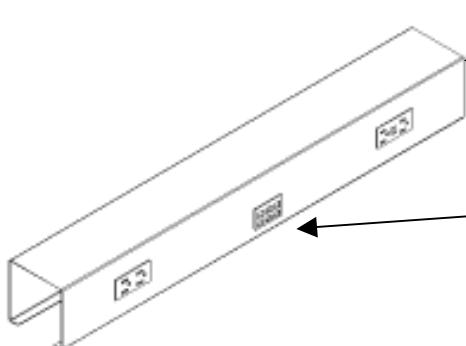

This add on Horizontal power chase allows for added connections. These are mounted in between the uprights. They are set up to be hardwired or used with modular power.

Data outlets can be punched per your request depending on your specified needs.

All horizontal power chases have access panels for easy installation and upkeep. Panels are easy to remove and replace.

Top Cap & Top Horizontal Stretcher selection:

Discovery Bench System – Top caps snap into top of uprights to seal off. The top stretchers are recommended when not using shelves to tie everything together. For LT version 2"x3" add –LT to the end of the part number.

TOP CAP SELECTION CHART

PART NO.	DISCRIPTION	SIZE DxW
006-026-CSC	Carbon steel snap in top cap powder coated to match structure.	6"x2"
006-026-SSC	304 stainless steel with a brushed finish snap in top cap	6"x2"
LT6-026-CSC	Carbon steel snap in top cap powder coated to match structure.	3"x2"
LT6-026-SSC	304 stainless steel with a brushed finish snap in top cap	3"x2"

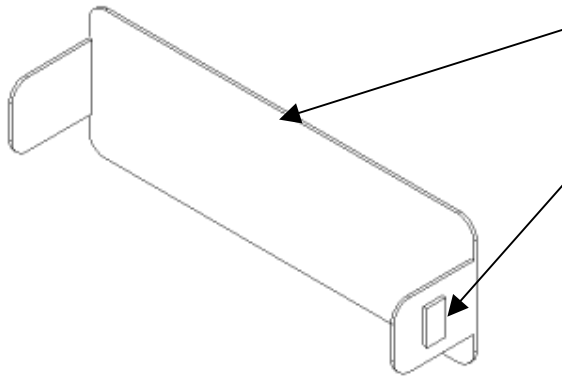

The top cap is manufactured from the same material as the bench. So if your using the standard components this will be carbon steel Powder coated with a determined finish.

typical of the stainless steel version as well. Caps are used where plumbing and wiring are not being strung through the upright.

Easy Breathe Bench Systems©

Discovery Bench System – The Easy Breathe Bench System© built in odor and fume removal system off the bench work surface. This assembly is mounted just above the work area to remove odors or annoying fumes. The system uses fans and carbon charged filters. All fans and filters are accessible through the back of the system. This system also carries plumbing, power, and data as add in options.

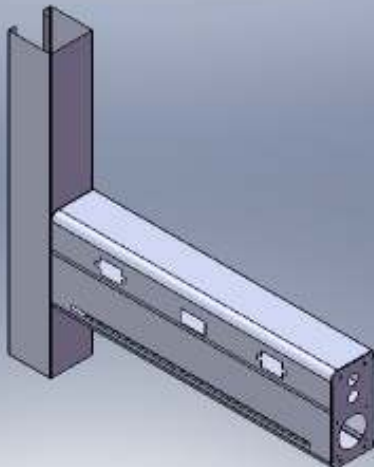

Easy Breathe Bench System Sizing Chart

PART NO.	SIZE	DISC.
1DS-024-EBS	24"w x6"d x 36"h	Bolt on assembly
1DS-030-EBS	30"w x6"d x 36"h	Bolt on assembly
1DS-036-EBS	36"w x6"d x 36"h	Bolt on assembly
1DS-042-EBS	42"w x6"d x 36"h	Bolt on assembly
1DS-048-EBS	48"w x6"d x 36"h	Bolt on assembly
1DS-054-EBS	54"w x6"d x 36"h	Bolt on assembly
1DS-058-EBS	58"w x6"d x 36"h	Bolt on assembly
1DS-060-EBS	60"w x6"d x 36"h	Bolt on assembly

Discovery™ series Easy Breathe Bench System© add on.

Panels Bench Back:

Discovery & LT Bench Systems – Typically used on single sided benches.
Panel backs conceal Bridge to Floor

BACK PANEL PAINTED STEEL		
PART NO.	DISCRIPTION	SIZE DxWxH
006-024-PBB	Panel end powder coated steel	1"x24"x23"
006-030-PBB	Panel end powder coated steel	1"x30"x23"
006-036-PBB	Panel end powder coated steel	1"x36"x23"
006-048-PBB	Panel end powder coated steel	1"x48"x23"
006-054-PBB	Panel end powder coated steel	1"x54"x23"
006-060-PBB	Panel end powder coated steel	1"x60"x23"

Note: Stainless steel type 304 will have a number four type finish.

BACK PANEL STAINLESS STEEL		
PART NO.	DISCRIPTION	SIZE DxWxH
006-024-PBB-SS	Panel end stainless steel type 304	1"x24"x23"
006-030-PBB-SS	Panel end stainless steel type 304	1"x30"x23"
006-036-PBB-SS	Panel end stainless steel type 304	1"x36"x23"
006-048-PBB-SS	Panel end stainless steel type 304	1"x48"x23"
006-054-PBB-SS	Panel end stainless steel type 304	1"x54"x23"
006-060-PBB-SS	Panel end stainless steel type 304	1"x60"x23"

BENCH BACK PANEL TO TOP PAINTED STEEL		
PART NO.	DISCRIPTION	SIZE DxWxH
006-024-PBB	Panel bench back to top steel w/ powder finish	1"x24"x40"
006-030-PBB	Panel bench back to top steel w/ powder finish	1"x30"x40"
006-036-PBB	Panel bench back to top steel w/ powder finish	1"x36"x40"
006-048-PBB	Panel bench back to top steel w/ powder finish	1"x48"x40"
006-054-PBB	Panel bench back to top steel w/ powder finish	1"x54"x40"
006-060-PBB	Panel bench back to top steel w/ powder finish	1"x60"x40"

BENCH BACK PANEL TO TOP STAINLESS STEEL		
PART NO.	DISCRIPTION	SIZE DxWxH
006-024-BBC-SS	Panel bench back to top stainless steel type 304	1"x24"x40"
006-030-BBC-SS	Panel bench back to top stainless steel type 304	1"x30"x40"
006-036-BBC-SS	Panel bench back to top stainless steel type 304	1"x36"x40"
006-048-BBC-SS	Panel bench back to top stainless steel type 304	1"x48"x40"
006-054-BBC-SS	Panel bench back to top stainless steel type 304	1"x54"x40"
006-060-BBC-SS	Panel bench back to top stainless steel type 304	1"x60"x40"

Note: For special height just insert the size into the part number such as 006-050-045-BBC-SS. This would result in a 50" wide panel by 45" tall.

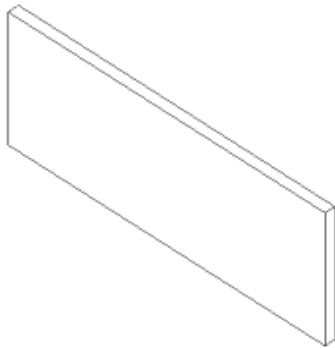

Closure also is used to seal off back of casework when open in the back. For use see figure 3.

Privacy Panels:

Discovery Bench System – Typically used on double-sided benches.

Privacy Panels include mounting brackets

PRIVACY PANEL PAINTED STEEL KIT

PART NO.	DISCRIPTION	SIZE DxWxH
006-022-030-S?	Panel privacy powder coated steel	1"x22"x30"
006-028-030-S?	Panel privacy powder coated steel	1"x28"x30"
006-034-030-S?	Panel privacy powder coated steel	1"x34"x30"
006-040-030-S?	Panel privacy powder coated steel	1"x40"x30"
006-046-030-S?	Panel privacy powder coated steel	1"x46"x30"
006-058-030-S?	Panel privacy powder coated steel	1"x58"x30"

? Add number for powder color for panels

PRIVACY PANEL STAINLESS STEEL KIT

PART NO.	DISCRIPTION	SIZE DxWxH
006-022-030-SS	Panel privacy stainless steel type 304	1"x22"x30"
006-028-030-SS	Panel privacy stainless steel type 304	1"x28"x30"
006-034-030-SS	Panel privacy stainless steel type 304	1"x34"x30"
006-040-030-SS	Panel privacy stainless steel type 304	1"x40"x30"
006-046-030-SS	Panel privacy stainless steel type 304	1"x46"x30"
006-058-030-SS	Panel privacy stainless steel type 304	1"x58"x30"

Note: Stainless steel will have a number four type finish.

PRIVACY PANEL FROSTED ACRYLIC

PART NO.	DISCRIPTION	SIZE DxWxH
006-022-040-FA	Panel privacy frosted acrylic panel	1"x22"x40"
006-028-040-FA	Panel privacy frosted acrylic panel	1"x28"x40"
006-034-040-FA	Panel privacy frosted acrylic panel	1"x34"x40"
006-040-040-FA	Panel privacy frosted acrylic panel	1"x40"x40"
006-046-040-FA	Panel privacy frosted acrylic panel	1"x46"x40"
006-058-040-FA	Panel privacy frosted acrylic panel	1"x58"x40"

PRIVACY PANEL SLAT WALL

PART NO.	DISCRIPTION	SIZE DxWxH
006-022-040-SW	Panel privacy slat wall	1"x22"x40"
006-028-040-SW	Panel privacy slat wall	1"x28"x40"
006-034-040-SW	Panel privacy slat wall	1"x34"x40"
006-040-040-SW	Panel privacy slat wall	1"x40"x40"
006-046-040-SW	Panel privacy slat wall	1"x46"x40"
006-058-040-SW	Panel privacy slat wall	1"x58"x40"

For special privacy panel sizes just change the last two digits in the part number like 006-022-040-SS change to 12" high. The new part number will be 006-022-012-SS.

MATERIALS:

- Glass frosted & smoked
- Laminate
- Plastic
- Epoxy resin
- Wood
- Polyresin®
- Slat wall
- Marker boards

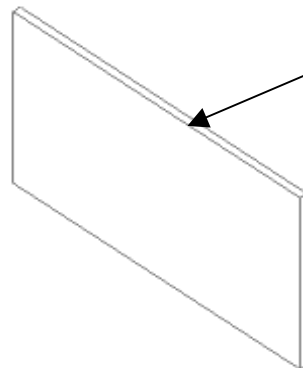

Privacy panels run from the work surface up to the top of the uprights vertically. There attached between the uprights using channel or angles. We offer special sizes and materials as needed.

Each panel comes with its own installation kit. Included in the kit are mounting brackets and screws.

Note: Privacy panels can be manufactured from laminate, veneer, frosted glass, smoked glass, epoxy resin, and plastic. All mentioned materials come with a mounting kit.

End Panels:

Discovery Bench System – Used on end of bench runs fastened to vertical uprights.
End Panels include mounting brackets

30 END PANEL STAINLESS STEEL KIT		
PART NO.	DISCRIPTION	SIZE DxWxH
006-024-030-SS	Panel end powder coated steel	1"x24"x30"
006-030-030-SS	Panel end powder coated steel	1"x30"x30"
006-036-030-SS	Panel end powder coated steel	1"x36"x30"
006-048-030-SS	Panel end powder coated steel	1"x48"x30"
006-054-030-SS	Panel end powder coated steel	1"x54"x30"
006-060-030-SS	Panel end powder coated steel	1"x60"x30"

Stainless steel type 304 with a number brushed finish.

Note: Stainless steel type 304 will have a number four type finish.

For special end panel sizes just change the last two digits in the part number like 006-022-040-EPS change to 12" high. The new part number will be 006-022-012-EPS.

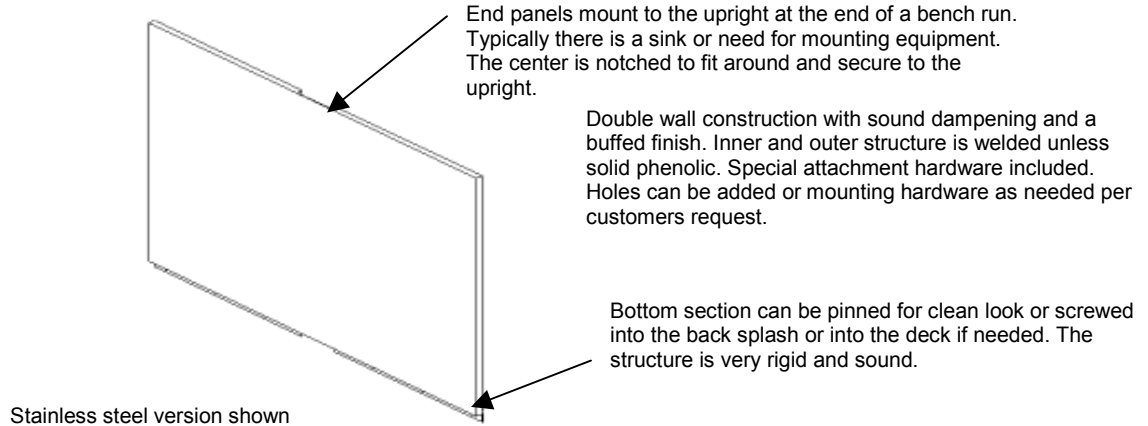

Panel materials not listed above include clear acrylic and frosted acrylic panels. These panels can have radius corners and special shapes as specified.

Shelves:

Bench Systems –
Shelf selection guide

STEEL STANDARD 13" or 15" DEEP SHELF SELECTION CHART		
PART NO.	DISCRIPTION	SIZE
006-0##-036	Standard steel shelf w/ 2" high back	"A"x6"x36"
006-0##-042	Standard steel shelf w/ 2" high back	"A"x6"x42"
006-0##-048	Standard steel shelf w/ 2" high back	"A"x6"x48"
006-0##-054	Standard steel shelf w/ 2" high back	"A"x6"x54"
006-0##-060	Standard steel shelf w/ 2" high back	"A"x6"x60"

STEEL STANDARD 13" or 15" DEEP SEISMIC SHELF SELECTION CHART		
PART NO.	DISCRIPTION	SIZE
006-0##-036-SS	Steel shelf w/ 2" high back & 1" sides	"A"x6"x36"
006-0##-042-SS	Steel shelf w/ 2" high back & 1" sides	"A"x6"x42"
006-0##-048-SS	Steel shelf w/ 2" high back & 1" sides	"A"x6"x48"
006-0##-054-SS	Steel shelf w/ 2" high back & 1" sides	"A"x6"x54"
006-0##-060-SS	Steel shelf w/ 2" high back & 1" sides	"A"x6"x60"

STEEL STANDARD 13" or 15" DEEP GRAVITY FEED SHELF SELECTION CHART

PART NO.	DISCRIPTION	SIZE
006-0##-036-GF	Steel shelf w/ 2" high front w/ angle adjustment	"A"x6"x36"
006-0##-042-GF	Steel shelf w/ 2" high front w/ angle adjustment	"A"x6"x42"
006-0##-048-GF	Steel shelf w/ 2" high front w/ angle adjustment	"A"x6"x48"
006-0##-054-GF	Steel shelf w/ 2" high front w/ angle adjustment	"A"x6"x54"
006-0##-060-GF	Steel shelf w/ 2" high front w/ angle adjustment	"A"x6"x60"

Note: The 5 prefix indicates component to be type 30304-stainless steel with a number 4 finish. For example your stainless steel part number would be 506-015-036-GF.

Seismic shelf not shown, same as standard except with a rail all across front.

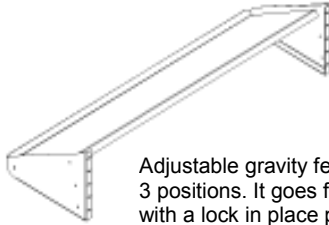

Adjustable gravity feed shelf. The shelf has 3 positions. It goes from flat to 15° to 30° with a lock in place pin system. It's a very user-friendly system.

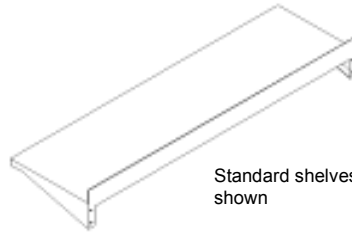

Standard shelves shown

Bench System –

Shelf selection guide (Universal style shelving also used with wall mount standards)

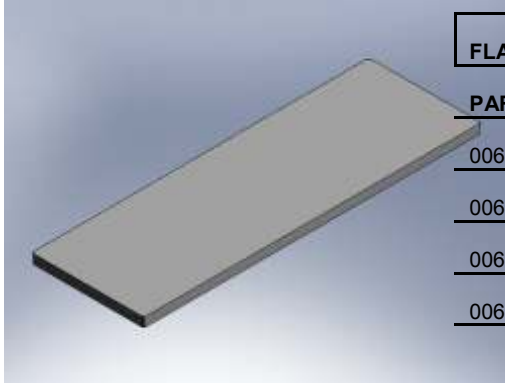

FLAT SHELVES PHENOLIC, EPOXY, AND LAMINATE 6", 12", 13", AND 18" DP

PART NO.	DISCRIPTION	FINISH
006-FSL-024	24" Wide shelf typically 1" thick material TBD	TBD
006-FSL-030	30" Wide shelf typically 1" thick material TBD	TBD
006-FSL-036	36" Wide shelf typically 1" thick material TBD	TBD
006-FSL-048	48" Wide shelf typically 1" thick material TBD	TBD
<i>All are made from either stainless steel or plated steel</i>		

Flat shelving manufactured from steel, stainless steel, epoxy, phenolic, laminate, and glass.

Shelves:

Bench Systems –

Shelf selection guide

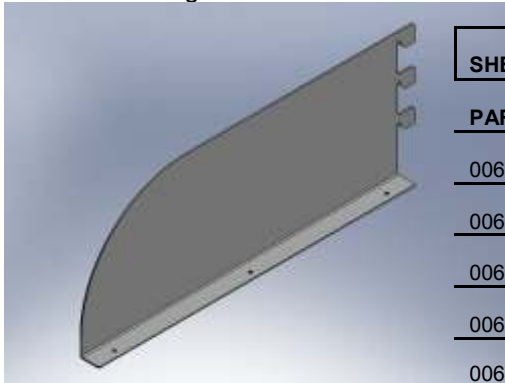

SHELF HANGER BRACKETS (BOOK END STYLE) Sold in pairs

PART NO.	DISCRIPTION	FINISH
006-BEB-006	6" x 6" x 1" wide material steel with a powder coat finish	TBD
006-BEB-012	6" x 12" x 1" wide material steel with a powder coat finish	TBD
006-BEB-013	6" x 13" x 1" wide material steel with a powder coat finish	TBD
006-BEB-018	6" x 18" x 1" wide material steel with a powder coat finish	TBD
006-BEB-024	6" x 24" x 1" wide material steel with a powder coat finish	TBD

Book end style Hanger brackets used for supporting steel, laminate, glass, epoxy, phenolic, and stainless steel (sold in pairs)

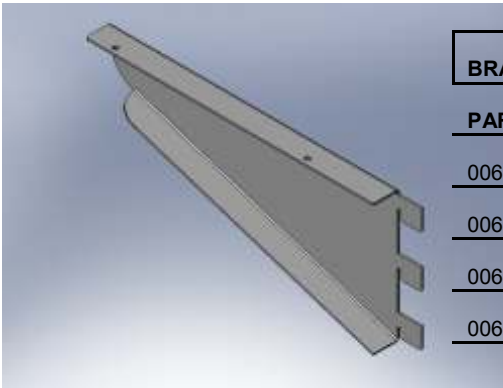

BRACKETS UNDER MOUNT TYPE (Sold in pairs)		
PART NO.	DISCRIPTION	FINISH
006-UMB-006	6" x 1" wide material steel with a powder coat finish	TBD
006-UMB-012	6" x 1" wide material steel with a powder coat finish	TBD
006-UMB-018	6" x 1" wide material steel with a powder coat finish	TBD
006-UMB-024	6" x 1" wide material steel with a powder coat finish <i>All are made from either stainless steel -SS or steel</i>	TBD

Under mount shelf bracket used to support flat steel, laminate, epoxy, and phenolic shelving. (sold in pairs)

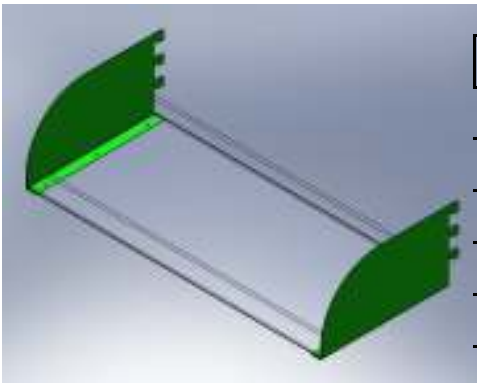

FLAT SHELVES GLASS TYPICALLY 6", 12", 13", AND 18"DP		
PART NO.	DISCRIPTION	FINISH
006-FSL-G24	24" Wide shelf typically 1" thick material 1/4" TEMPERED	TBD
006-FSL-G30	30" Wide shelf typically 1" thick material 1/4" TEMPERED	TBD
006-FSL-G36	36" Wide shelf typically 1" thick material 1/4" TEMPERED	TBD
006-FSL-G48	48" Wide shelf typically 1" thick material 1/4" TEMPERED <i>All glass is trimmed with stainless steel channels typically</i>	TBD

Glass shelves (glass shelf shown with rails)

Plumbing:

Bench Systems – Can be plumbed with a quick disconnect type plumbing system for vacuum, air, gas, and other lab special gases or liquids. These same systems are also offered in our Over Head Service Centers. This also allows the plumbing to be daisy chained from bench to bench. We are currently using Water Saver Company© and Staubli© products to complete bench modules when requested.

This system allows for your mobile benches to remain mobile even if they are set up to supply plumbing services.

For further information and design options contact your local dealer or representative.

Power:

Bench System –

Besides built in power there are other add on options for external applications to distribute power. These systems add unique flexibility to our vast bench and table systems. This is only a guide if there are specific products you prefer to use just contact your dealer or representative.



Various lengths of Wiremold® power strips
(add to tables and benches as needed) Option E

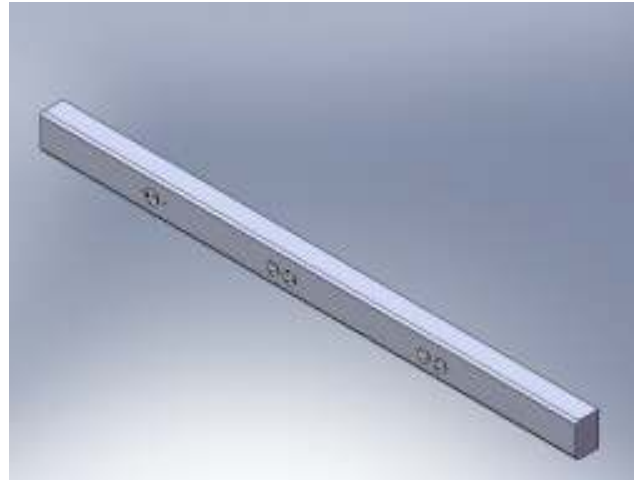

Various lengths of Wiremold® and
Starline® flexible power races Option D

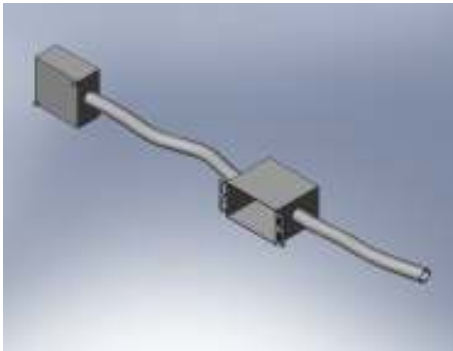

Option A

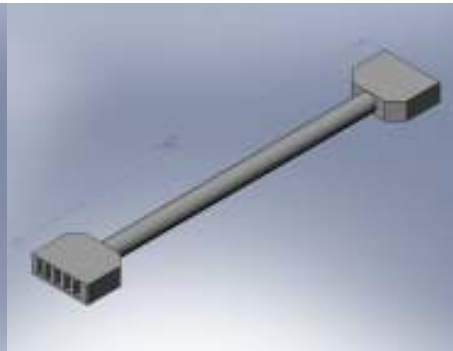

Option B

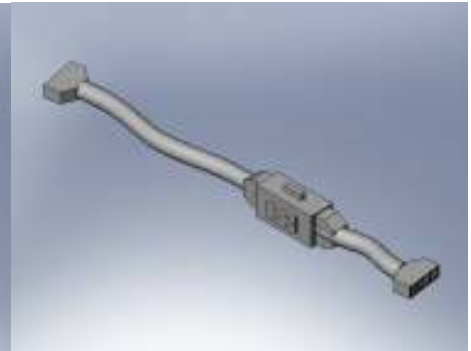

Option C

Power selection for benches:

There are three options available for power concerning bench models. All benches that have the power option can use either external services from above Options D & E or one of three options listed below.

Option One – power will be wired using option A that wires one or two outlets back to a junction box. If double sided then there will be two sets but one junction box. This option can also wire each outlet on a separate circuit if required. Then if benches are daisy chained together wire all back to main connection point. This can also be wired to the junction box and then have a plug or pig tail out of the “j” box based on customer requests.

Option Two – Modular power using internal wiring back to one junction box with a connection to each bench through a modular plug connection option B.

Option Three – Modular power all the way through the bench. Typical applications for 2 circuits with the option up to 4. Benches can be simply plugged together up to 4 per circuit. See option C for modular power option.

When specifying bench systems just select a power option or you can always option out completely and have your electrical contractor handle the installation. Or have us at least load the appropriate electrical devices that are specified.

Typically we handle this portion of the benches on a project to project basis. We also offer European components if specified. Final wiring will be performed by appropriate trades in their respective country according to their own local codes and specifications.

Over head Service Centers:

Lynx overhead Bench Support Systems – Steel fabricated enclosures that house plumbing, data, electrical, lighting, and exhaust when required. These systems can be isolated to keep power and plumbing segregated based on code requirements. These systems unless ceiling tile type will have Unistrut® internally to strengthen the framework and help carry the power and plumbing. Each system is custom built to meet the requirements.

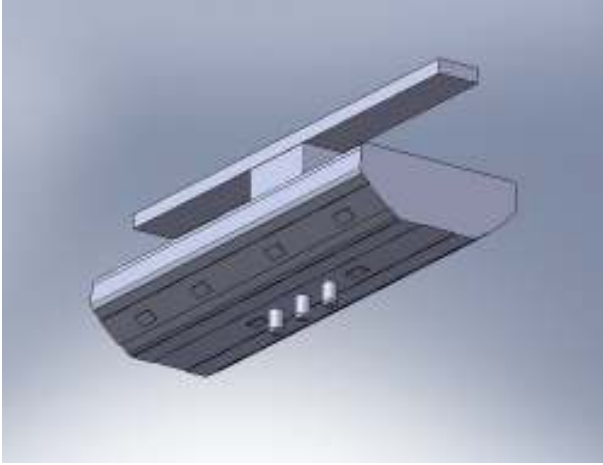

Lynx standard over head service center 60" long

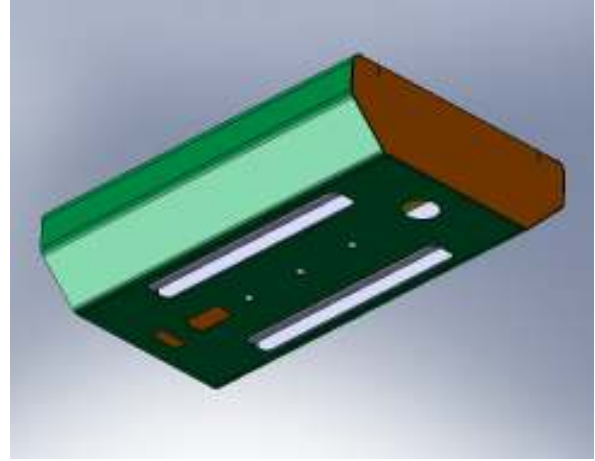

Lynx standard overhead service center 36" long

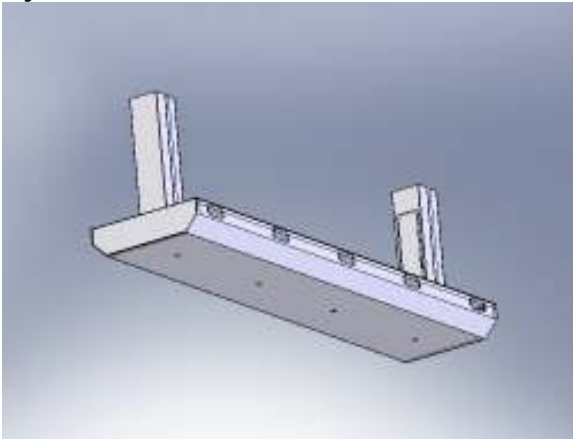

Over head Lynx 96" long service center

LYNX CEILING SERVICE CENTERS (Systems can be daisy chained together)		
PART NO.	DISCRIPTION	SIZE
LNX-036-CSC	Ceiling mounted service centers	24"x36"
LNX-048-CSC	Ceiling mounted service centers	24"x48"
LNX-060-CSC	Ceiling mounted service centers	24"x60"
LNX-072-CSC	Ceiling mounted service centers	24"x72"
LNX-096-CSC	Ceiling mounted service centers	24"x96"

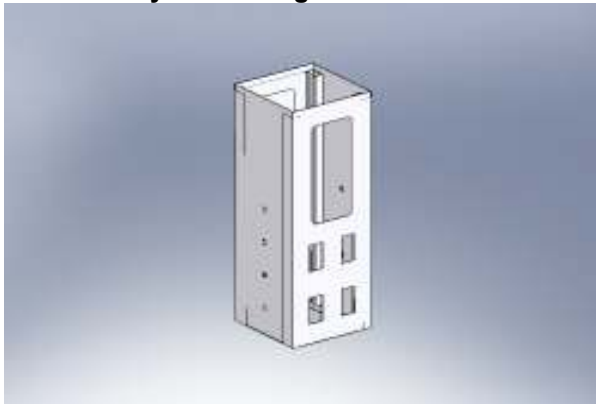

Post Style Lynx System service center
#LNX-010-036

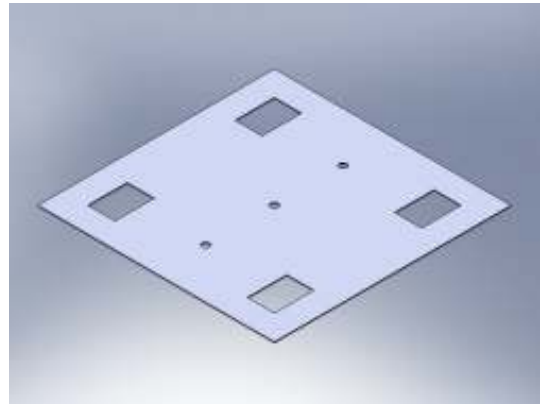

Drop in style ceiling tile service center
(concealed option not shown) #LNX-024-024

The standard post and service center configurations are manufactured from steel whereas the drop in style panel is aluminum unless specified.

For more details and installation instructions contact your sales representative.

Vision Series Over head Service Centers:

Vision overhead Bench Support Systems – Steel fabricated enclosures that house plumbing, data, electrical, lighting, and exhaust when required. These systems can be isolated to keep power and plumbing segregated based on code requirements. These systems will have Unistrut© internally to strengthen the frame work and help carry the power and plumbing. Each system is typically custom built to meet the requirements. Each system also houses fluorescent or LED lights.

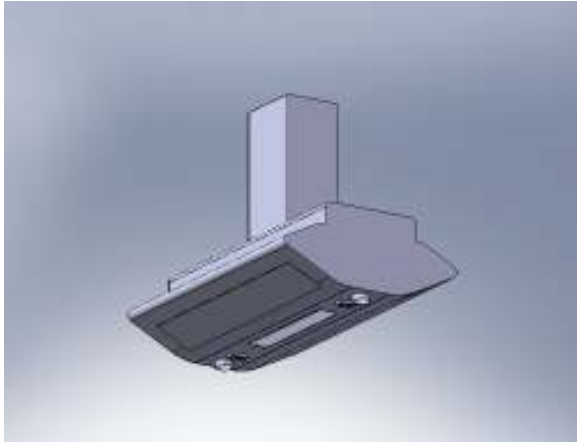

Vision Service Centers model #VIS-048-CSC

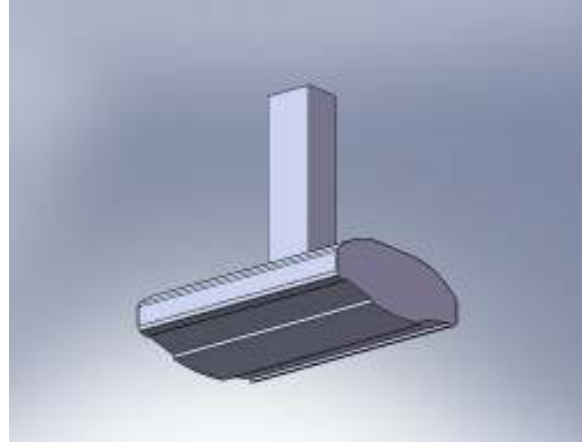

Model #VIS-148-CSC

Wall Standards:

These wall standards are manufactured to be used in laboratory settings either stand alone or with one of the bench systems. The slotted features of the bench is carried over to the wall standard. This allows the end user to move shelving systems from the wall to the bench and back again. The standards are manufactured from 14 gauge steel and 16 gauge 304 brushed stainless steel. The standards are also manufactured in single slot and double slot configurations.

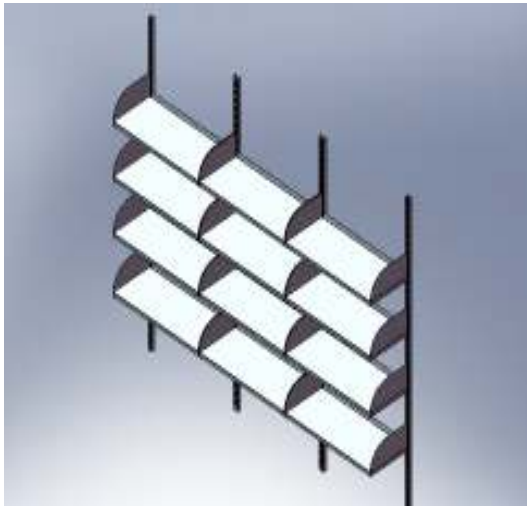

Wall standards (for stainless steel add 10S- to first three digits in prt #)		
PART NO.	DISCRIPTION	SIZE
100-WST-024	Standard wall mounted steel single slot	1"x24"
100-WST-024-DS	Standard wall mounted steel double slot	1-1/2"x24"
100-WST-030	Standard wall mounted steel single slot	1"x30"
100-WST-030-DS	Standard wall mounted steel double slot	1-1/2"x30"
100-WST-036	Standard wall mounted steel single slot	1"x36"
100-WST-036-DS	Standard wall mounted steel double slot	1-1/2"x36"
100-WST-048	Standard wall mounted steel single slot	1"x48"
100-WST-048-DS	Standard wall mounted steel double slot	1-1/2"x48"
100-WST-084	Standard wall mounted steel single slot	1"x84"
100-WST-084-DS	Standard wall mounted steel double slot	1-1/2"x84"

Full height wall standards shown with bookend hanger brackets and steel shelves. It is recommended to use backing plates or at least tie in with wall studs. Spans typically should not exceed 48" if possible. Depth of shelves and materials used for shelving will also affect spacing.

FIGURE 3. Complete Discovery Bench Layout Side A

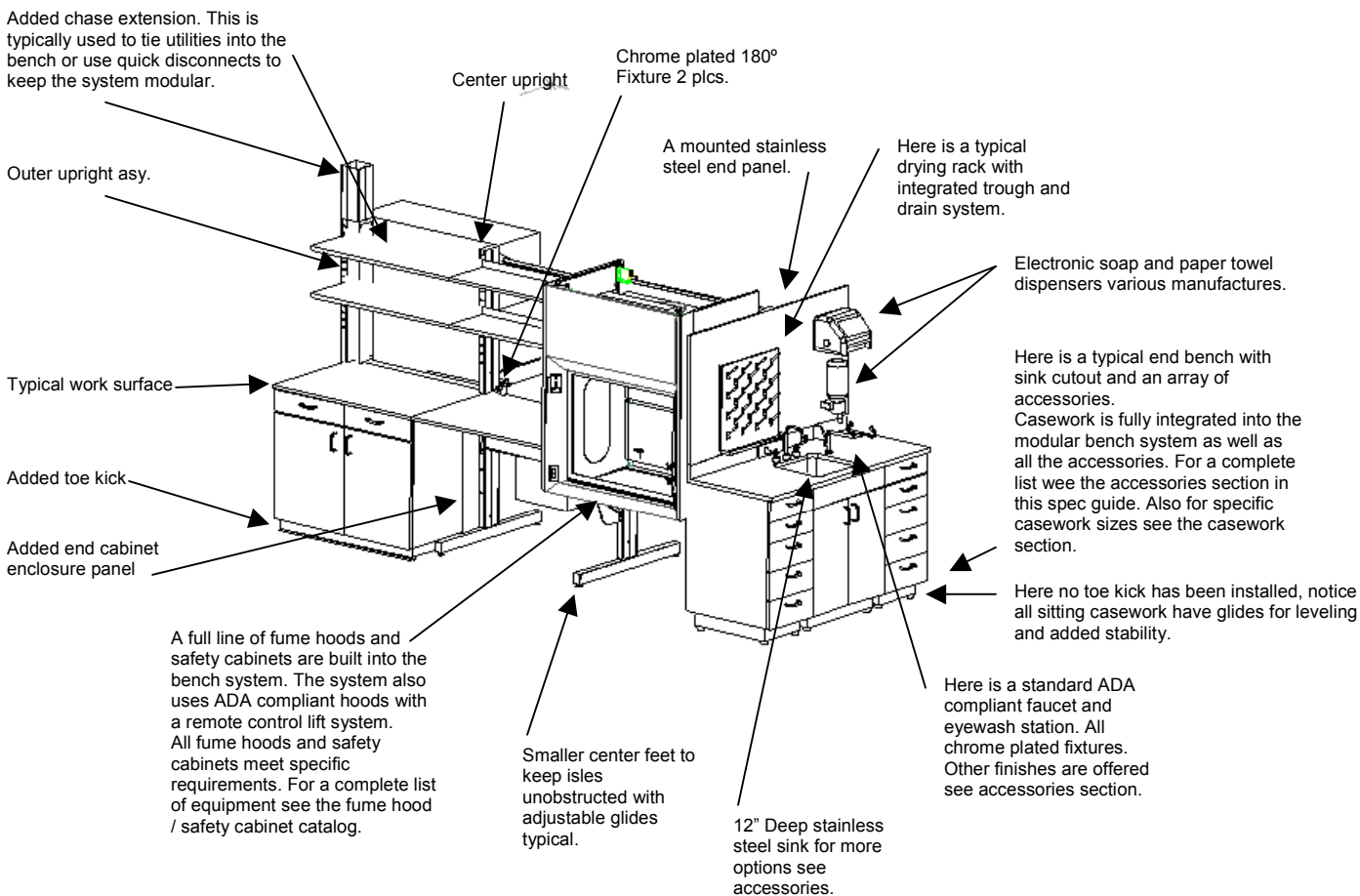

BENCH SYSTEMS CASEWORK

Steel, Plastic Laminate, Wood and Stainless Steel casework.

Accessories:

All Bench Systems –

Here is an additional list product for the bench systems. For a complete list, call us for details.

- **Snorkel Hoods**
- **Bench integrated fume removal system**
- **Monitor arms**
- **Under work surface PC holders**
- **Paper towel dispensers**
- **Soap dispensers**
- **Waste containment devices**
- **Drying racks, acrylic, stainless steel, phenolic, & epoxy resin**
- **Sinks, stainless steel, plastic, & epoxy resin various sizes**
- **Lighting, fluorescent, LED, and halogen**
- **Backer boards and slat wall**
- **Grommets for extra data and cabling through work surfaces**
- **Tables both static and mobile**
- **Reagent carts and standard utility carts**
- **Mobile work stations**
- **Safety fixtures, showers, eye wash, etc.**
- **Special storage ACID / FLAMMABLE cabinets various sizes**
- **Seating laboratory specific**
- **Data and power fixed and modular**

Distributed by:



Keur Industries, Inc.
18784 – 174th Avenue
Spring Lake, MI 49456

Ph: 616-846-6990
Fax: 616-846-6996
www.keurind.com

Keur Industries, Inc. Products:

Multi-Lab Laboratory Casework, Heritage Fume Hoods, Discovery Bench Systems

Copyright 2008 **Keur Industries Inc.** Contents property of **Keur Industries Inc.** May not be reproduced without permission. This document does not knowingly contain any untrue materials and products or omissions to cause misleading information or guidelines.